

Government Tender Bulletin

REPUBLIC OF SOUTH AFRICA

Vol. 509 Pretoria, 23 November 2007 **No. 2513**

This document is also available on the Internet on the following web sites:

1. <http://www.treasury.gov.za>
2. <http://www.info.gov.za/documents/tenders/index.htm>



AIDS HELPLINE 0800 123 22 Prevention is the cure

INDEX

	<i>Page No.</i>
Instructions	8
A. TENDERS INVITED FOR SUPPLIES, SERVICES AND DISPOSALS	
TENDERS WITH AN ESTIMATED VALUE OF <u>LESS THAN R75 000</u>	
▶ SUPPLIES: STATIONERY/PRINTING	11
▶ SERVICES: GENERAL	11
TENDERS WITH AN ESTIMATED VALUE OF <u>MORE THAN R75 000</u>	
▶ SUPPLIES: ACCOMMODATION, LEASING OF	11
▶ SUPPLIES: CLOTHING/TEXTILES	14
▶ SUPPLIES: FURNITURE	14
▶ SUPPLIES: GENERAL	16
▶ SUPPLIES: MEDICAL	16
▶ SUPPLIES: PERISHABLE PROVISIONS	16
▶ SUPPLIES: STATIONERY/PRINTING	17
▶ SERVICES: BUILDING	17
▶ SERVICES: FUNCTIONAL (INCLUDING CLEANING AND SECURITY SERVICES)	18
▶ SERVICES: GENERAL	20
▶ SERVICES: MECHANICAL	20
▶ SERVICES: PROFESSIONAL	20
▶ SERVICES: TRANSPORT	25
SPECIAL ADVERTISEMENTS	26
B. RESULTS OF TENDER INVITATIONS	
▶ SUPPLIES	47
▶ SERVICES	49
C. TENDER INVITATIONS FINALISED	51
D. TENDER INVITATIONS CANCELLED	51
F. ANNEXURES	
Annexure 1: Address list	53
Annexure 2: Important announcement to all departments concerned	63
Annexure 3: Subscription	64



Government Printing Works



Est. 1888

149 Bosman Street • Private Bag X85, Pretoria 0001, RSA

Tel: (012) 334-4504
Fax: (012) 323-8805
Reference **TENDER BULLETIN**Inquiries **ISTELLE PIENAAR**

TENDER INQUIRIES

Date: **FROM JANUARY 2005**Department, firm or institution: **ALL PUBLICATIONS**

The Tender Bulletin is available on the Internet on the following web sites:

1. <http://www.treasury.gov.za>
2. <http://www.info.gov.za/documents/tenders/index.htm>

E-mail: istelle.pienaar@gpw.gov.za

HOW TO ADVERTISE IN THE GOVERNMENT TENDER BULLETIN

1. **FORM No. 1:** This form must always be submitted to us when you want to advertise in the tender bulletin. Your tender description in the 1st column.

The place where and/or which Department requires the tender in the 2nd column

The Department Tender No. in the 3rd column. Each Department allocate their own Tender numbers.

The tender closing date in the 4th column—the closing date should be 4–6 weeks from publication date, except with special recognition from the Tender Board.

Your address list number (which we will submit to you after you have completed Form No. 2) in the 5th and 6th columns.

If the tender closes at the Tender Board's Offices, their number (Tender Board's number) should appear in Column 6.
2. **FORM No. 2:** Complete this form together with Form No. 1, when you advertise for the first time, to receive your own tender address list number.
3. **FORM No. 3:** This form is only for your own records, choose from this list the right section under which you want your tender to be published and write this section in at the space provided next to Supplies:..... Services:..... Disposals:..... on Form No. 1 (also mark with an X next to less than R75 000 or more than R75 000, whichever is applicable).

NOTES:

1. Advertisements are submitted directly to Government Printing Works: Complete the necessary forms and fax it to above-mentioned fax.
2. Request cost calculations from Levy Mhlanga at Tel: (012) 334-4619.
3. Please note that we will **not accept any late advertisements** after the closing time—the advertisements closes the Friday before the publication date at 15:00. The *Tender Bulletin* appears every Friday, except when there is a Public Holiday involved, then the closing date for acceptance of tenders will be forwarded with one day. These publication dates that influences the closing dates of the *Tender Bulletin*, are published for your convenience at the back of each *Tender Gazette*.
4. For any enquiries regarding your account or account number, please contact Leona Willemse at Tel. (012) 334-4605/4.
5. The tariff for publication is R85 per cm and R2 125 per A4 page (including VAT).
6. Subscription rates for hard copies: Local—R34,20 per annum; Overseas—R40 per annum.
7. Subscribe by phoning S. Milanzi, Tel. (012) 334-4735 or J. Wehmeyer, Tel. (012) 334-4734. A soft copy can be obtained from the Internet at: <http://www.gov.z/tenders/> or <http://www.treasury.gov.za>
8. NB: No *Special Tender Bulletins* are published any more!
9. All Tender information on the Website is handled by Mr Joe Cronje, Tel. 334-4690.
10. **Last advertisement date for the year 2007:** 14 December 2007 (for bids closing the week of 21 January 2008, advertisements to reach Government Printers on 7 December 2007)
Last closing date of bids for 2007: 14 December 2007 (advertised on 9 November 2007 and the advertisement must reach Government Printer on 2 November 2007)
First advertising date for 2008: 18 January 2008 (Advertisements to reach Government Printers on 7 December 2007)
First closing date of bids for 2007: 21 January 2008.
NOTE: CONTRACT MANAGEMENT: Tender Information Center will be closed from 24 to 31 December 2007.
11. Note that all advertisements will be published as received and any or all information will be published as on hard copy. We will not take any responsibility if wrong copy was sent in, or if bad copies are received! No telephonic changes will be made!
12. **PLEASE NOTE: All changes (corrections on advertisements), as well as any other inquiries about the advertisements in future, will be handled by Mrs Istelle Pienaar at our Advertisement Section, Tel. (012) 334-4504.**

ADDRESS LIST

TENDERS OBTAINABLE FROM:

Name of Department:

Street Address:

.....

.....

Postal Address:

.....

.....

Enquiries:

Tel. No. Fax No.

Office hours:(Mondays to Fridays)

POST OR DELIVER TENDERS TO:

Name of Department:

Street Address:

.....

.....

Postal Address:

.....

.....

Tender Box Address
(main entrance, reception
area or room no. of the
building):

Enquiries:

Tel. No. Fax No.

PLEASE INFORM US OF ANY CHANGES

CATEGORIES FOR OWN USE: CHOOSE ONE AND MARK CLEARLY ON FORM 1
--

LESS THAN R75 000	MORE THAN R75 000
SUPPLIES	SUPPLIES
ACCOMMODATION, Leasing of	ACCOMMODATION, Leasing of
AUDIO-VISUAL EQUIPMENT	AUDIO VISUAL EQUIPMENT
BUILDING MATERIAL	BUILDING MATERIAL
CHEMICALS: Agricultural/Forestry/Laboratory/ Water Care	CHEMICALS: Agricultural/Forestry/Laboratory/ Water Care
CLOTHING/TEXTILES	CLOTHING/TEXTILES
COMPUTER EQUIPMENT	COMPUTER EQUIPMENT
COMPUTER SOFTWARE	COMPUTER SOFTWARE
ELECTRICAL EQUIPMENT	ELECTRICAL EQUIPMENT
ELECTRONIC EQUIPMENT	ELECTRONIC EQUIPMENT
FURNITURE	FURNITURE
GENERAL	GENERAL
MEDICAL	MEDICAL
OFFICE EQUIPMENT: Labour-saving devices	OFFICE EQUIPMENT: Labour-saving devices
PERISHABLE PROVISIONS	PERISHABLE PROVISIONS
STATIONERY/PRINTING	STATIONERY/PRINTING
STEEL	STEEL
TIMBER	TIMBER
VEHICLE (all types)	VEHICLE (all types)
WORKSHOP EQUIPMENT	WORKSHOP EQUIPMENT
SERVICES	SERVICES
BUILDING	BUILDING
CIVIL	CIVIL
ELECTRICAL	ELECTRICAL
FUNCTIONAL (including cleaning/security services)	FUNCTIONAL (including cleaning/security services)
GENERAL	GENERAL
MAINTENANCE (Electrical, mechanical equipment and plumbing)	MAINTENANCE (Electrical, mechanical equipment and plumbing)
MECHANICAL	MECHANICAL
PROFESSIONAL	PROFESSIONAL
REPAIR AND MAINTENANCE OF VEHICLES	REPAIR AND MAINTENANCE OF VEHICLES
TRANSPORT	TRANSPORT
DISPOSALS	DISPOSALS
CLOTHING AND TEXTILES	CLOTHING AND TEXTILES
FURNITURE	FURNITURE
GENERAL	GENERAL
SCRAP METAL	SCRAP METAL
VEHICLES	VEHICLES
RESULTS	RESULTS
SUPPLIES	SUPPLIES
SERVICES	SERVICES
DISPOSALS	DISPOSALS
FINALISED	
CANCELLED	
REGISTRY OF POTENTIAL SUPPLIERS	

INSTRUCTIONS

Please note the following:

1. Tenderers are advised to read the entire *Government Tender Bulletin*. No officer of any Procurement Activity will be held responsible for loss of a potential opportunity to tender due to possible incorrect categorising of requirements.
2. **Requests are categorised separately for tenders with estimated values of less than R75 000 and more than R75 000.**
3. Tenders for the procurement of supplies, services and disposals are categorised as follows:

SUPPLIES

- (i) Accommodation, leasing of
- (ii) Audio visual equipment
- (iii) Building material
- (iv) Chemicals: Agricultural/Forestry/
Laboratory/Water Care
- (v) Clothing/Textiles
- (vi) Computer equipment
- (vii) Computer software
- (viii) Electrical equipment
- (ix) Electronic equipment
- (x) Furniture
- (xi) General
- (xii) Medical
- (xiii) Office equipment: Labour-saving devices
- (xiv) Perishable provisions
- (xv) Stationary/printing
- (xvi) Steel
- (xvii) Timber
- (xviii) Vehicle (all types)
- (xix) Workshop equipment

SERVICES

- (i) Building
- (ii) Civil
- (iii) Electrical
- (iv) Functional (including cleaning-,
and security services)
- (v) General
- (vi) Maintenance of electrical, mechanical
equipment and plumbing
- (vii) Mechanical
- (viii) Professional
- (ix) Repair and maintenance of vehicles
- (x) Transport

DISPOSALS

- (i) Clothing and textiles
- (ii) Furniture
- (iii) General
- (iv) Scrap metal
- (v) Vehicles

4. Tender documents are generally available in **English** only.
5. The addresses at which tender documents may be obtained and to which tenders should be posted, appear in **Annexure 1**.
- 5.1 The address where a document is available from and where it must be submitted to may differ.
- 5.2 Tenderers should read the Conditions of Tender issued by the different tender boards. Mostly tenders that are submitted after the closing time will not be allowed for consideration.
6. The financial category for construction related supplies and services are the following:
 - A: To R300 000**
 - B: R300 000 to R2 000 000**
 - C: R2 000 000 to R6 000 000**
 - D: Above R6 000 000**
- 6.1 Where security is required particulars thereof are indicated in the tender documents. However, security is mostly not required for services with an estimated value of less than R100 000.
7. Please note that all documents issued by the Department of Public Works will be sold as follows:
 - R50,00 per set for all services with a pre-estimated value from above R100 000 to R300 000.
 - R100,00 per set for all services with a pre-estimated value above R300 000 to R2 000 000.
 - R200,00 per set for all services with a pre-estimated value above R2 000 000.

These amounts will not be refunded. Only cash or postal orders will be accepted.
- 7.1 **No documents will be exchanged.**
8. Tenders must be on the official tender forms which must be filled in and completed in all respects.
9. Tenders must be submitted in sealed envelopes.
10. Separate envelopes must be used for each tender invitation.
11. The address, tender number and closing date must appear on the **front** of the envelope.
12. The name and address of the tenderer must appear on the **back** of the envelope only.
13. Also consult at least the two previous issues in order to obtain full particulars of all current tender invitations.

NATIONAL TREASURY

STATE TENDER BOARD TENDERS

CONTACT DETAILS:

CONTRACT MANAGEMENT: The Chief Director: Contract Management, 240 Vermeulen Street (corner of Andries and Vermeulen Streets), Pretoria.

Postal address: Private Bag X115, Pretoria, 0001, Tel. (012) 315-5377
Fax (012) 315-5388, 315-5400 or 315-5058.

Office hours: 07:30–12:30 and 13:15–16:00 (Monday to Friday)

FOR COLLECTION OF BID DOCUMENTS:

Tender Information Centre, 240 Vermeulen Street (Ground Floor), behind ABSA Bank (corner of Andries and Vermeulen Streets), Pretoria.

Postal address: Private Bag X115, Pretoria, 0001.

Enquiries: Helpdesk: Tel. (012) 315-5858 or (012) 315-5732
Fax (012) 315-5734.

Web address: www.treasury.gov.za or www.globalerfx.com

ELECTRONIC BIDS:

Potential bidders can also bid electronically. Please visit the following website: www.globalerfx.com or visit Tender Information Centre, 240 Vermeulen Street, Pretoria, Tel. (012) 315-5858 for more information.

A free one day training session is offered to bidders who wish to bid electronically and will take place every Tuesday and Thursday afternoons at 14:00–16:00. These sessions will be held at the Offices of Intenda in Centurion.

Bookings are essential.

Please contact the Help Desk for further information at Tel. (012) 663-8815.

The Intenda Help Desk will be available on weekdays between 08:00 and 17:00, Tel. (012) 663-8815 and Saturday and Sunday from 09:00 am till 18:00 pm. Tel. 083 554 9330/1 for assistance regarding bid responses on the website. Please note that no voice messages will be returned.

IMPORTANT NOTICE TO PROSPECTIVE BIDDERS:

- It is the responsibility of prospective bidders to ensure that their bid documents are submitted before the closing time and date of tender.
- Bids received after the closing time and date are late and will as a rule NOT be considered.
- Normally all bids close at 11:00 on the closing date as indicated on the bid document.
- Bids that are posted must reach the Contract Management before the closing time and date of the bid.
- The bid box is generally open 24 hours a day, 7 days a week.

CLOSING ADDRESS OF BIDS:

The Chief Director: Contract Management,
Tender Information Centre,
240 Vermeulen Street (Ground Floor),
behind ABSA Bank (corner Andries and Vermeulen Streets),
Pretoria.

Postal address: Private Bag X115, Pretoria, 0001.

Enquiries: Helpdesk: Tel. (012) 315-5858
Fax (012) 315-5734.

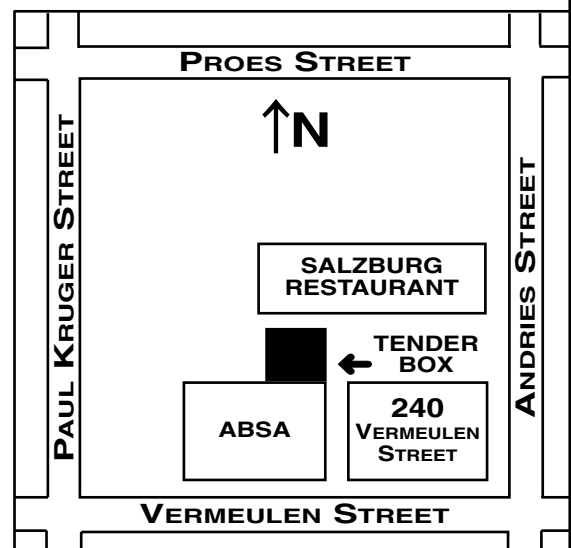

IMPORTANT NOTICE

**THE GOVERNMENT PRINTING WORKS WILL
NOT BE HELD RESPONSIBLE FOR ANY
ERRORS THAT MIGHT OCCUR IN THE
*TENDER BULLETIN***

**DUE TO
INCOMPLETE/INCORRECT/ILLEGIBLE COPY.**

**No FUTURE QUERIES WILL BE HANDLED
IN CONNECTION WITH THE
ABOVE.**

A. TENDERS INVITED FOR SUPPLIES, SERVICES AND DISPOSALS***TENDERS WITH AN ESTIMATED VALUE OF LESS THAN R75 000***

DESCRIPTION	REQUIRED AT	TENDER No.	DUE AT 11:00	TENDERS OBTAINABLE FROM	POST OR DELIVER TENDERS TO
				See Annexure 1, Page 53	

SUPPLIES: STATIONERY/PRINTING

<p>Amendment of tender closing date: Please note: All bids (GPW-W 03, GPW-S 12, GPW-S 13, GPW-S 18, GPW-S 19, GPW-S 20 GPW-S 21, GPW-S 22, GPW-D2007/10 and GPW-W04) advertised in the Tender Bulletin (Number 2511) on the 2007-11-09 will be closing on the 04-12-07 and not on the 09-12-2007 as indicated. Please note: A non-refundable payment of R20,00 is payable at Government Printing Works cashiers, Bosman Street, entrance before collecting bid documents. The receipt must be attached in the bid document when submitted on the date of closing</p>				64	64
<p>Please note: Bid number GPW-S 18 has been cancelled. Stock no longer required by client</p>					

SERVICES: GENERAL

Appointment of a service provider to determine a final regulatory action forms in terms of the Rotterdam Convention PIC procedure for banned and severely restricted chemicals in South Africa	Department of Environmental Affairs and Tourism, Pretoria	E 1120	2007-12-14	68	68
--	---	--------	------------	----	----

A. TENDERS INVITED FOR SUPPLIES, SERVICES AND DISPOSALS***TENDERS WITH AN ESTIMATED VALUE OF MORE THAN R75 000***

DESCRIPTION	REQUIRED AT	TENDER No.	DUE AT 11:00	TENDERS OBTAINABLE FROM	POST OR DELIVER TENDERS TO
				See Annexure 1, Page 53	

SUPPLIES: ACCOMMODATION, LEASING OF

<p>Letting of existing office accommodation comprising of 433 m² to public works for usage by SAPS (Stock Theft Unit) This bid will be evaluated in terms of:</p> <table border="1"> <tr> <td colspan="4">80/20 point scoring system</td> </tr> <tr> <td colspan="4">Preference: Price and quality/functionality</td> </tr> <tr> <td colspan="4">Historically Disadvantaged Individuals (HDI)</td> </tr> <tr> <td>Persons who had no franchise in the national elections before the 1983 and 1993 Constitutions</td> <td>10 points</td> <td>Price:</td> <td>60% (of 80)</td> </tr> <tr> <td>Who is a female</td> <td>6 points</td> <td>Quality/ Functionality:</td> <td>40% (of 80)</td> </tr> <tr> <td>Persons with disability</td> <td>4 point</td> <td></td> <td></td> </tr> <tr> <td>Other:</td> <td>20 points</td> <td></td> <td></td> </tr> <tr> <td>Total must equal:</td> <td>20 points</td> <td>Total must equal:</td> <td>100% (of 80)</td> </tr> </table> <p>No site inspection. NB: The department reserves the right not to award the contract. Note: Documents will be sold at a non-refundable deposit of R100,00 CASH per set. Contact for bid information: Polelo Maduwa, (013) 753-6300. General enquiries: Mr S Mlangeni, (013) 753-6300</p>	80/20 point scoring system				Preference: Price and quality/functionality				Historically Disadvantaged Individuals (HDI)				Persons who had no franchise in the national elections before the 1983 and 1993 Constitutions	10 points	Price:	60% (of 80)	Who is a female	6 points	Quality/ Functionality:	40% (of 80)	Persons with disability	4 point			Other:	20 points			Total must equal:	20 points	Total must equal:	100% (of 80)	Ermelo CBD	NST 07/039	2007-12-19	113	113
80/20 point scoring system																																					
Preference: Price and quality/functionality																																					
Historically Disadvantaged Individuals (HDI)																																					
Persons who had no franchise in the national elections before the 1983 and 1993 Constitutions	10 points	Price:	60% (of 80)																																		
Who is a female	6 points	Quality/ Functionality:	40% (of 80)																																		
Persons with disability	4 point																																				
Other:	20 points																																				
Total must equal:	20 points	Total must equal:	100% (of 80)																																		
Letting of new office accommodation comprising of 226.25 m ² and six parking bays to Public Works for the use by Land Affairs.	Nelspruit	NST 07/040	2007-12-19	113	113																																

DESCRIPTION	REQUIRED AT	TENDER No.	DUE AT 11:00	TENDERS OBTAINABLE FROM	POST OR DELIVER TENDERS TO																				
				See Annexure 1, Page 53																					
<p>This bid will be evaluated in terms of:</p> <p>80/20 point scoring system</p> <p>Preference: Price and quality/functionality</p> <p>Historically Disadvantaged Individuals (HDI)</p> <table border="0"> <tr> <td>Persons who had no franchise in the national elections before the 1983 and 1993 Constitutions</td> <td>10 points</td> <td>Price:</td> <td>60% (of 80)</td> </tr> <tr> <td>Who is a female</td> <td>6 points</td> <td>Quality/ Functionality:</td> <td>40% (of 80)</td> </tr> <tr> <td>Persons with disability</td> <td>4 point</td> <td></td> <td></td> </tr> <tr> <td>Other:</td> <td>20 points</td> <td></td> <td></td> </tr> <tr> <td>Total must equal:</td> <td>20 points</td> <td>Total must equal:</td> <td>100% (of 80)</td> </tr> </table> <p>No site inspection.</p> <p>NB: The department reserves the right not to award the contract.</p> <p>Note: Documents will be sold at a non-refundable deposit of R100,00 CASH per set.</p> <p>Contact for bid information: Polelo Maduwa, (013) 753-6300.</p> <p>General enquiries: Mr S Mlangeni, (013) 753-6300</p>	Persons who had no franchise in the national elections before the 1983 and 1993 Constitutions	10 points	Price:	60% (of 80)	Who is a female	6 points	Quality/ Functionality:	40% (of 80)	Persons with disability	4 point			Other:	20 points			Total must equal:	20 points	Total must equal:	100% (of 80)					
Persons who had no franchise in the national elections before the 1983 and 1993 Constitutions	10 points	Price:	60% (of 80)																						
Who is a female	6 points	Quality/ Functionality:	40% (of 80)																						
Persons with disability	4 point																								
Other:	20 points																								
Total must equal:	20 points	Total must equal:	100% (of 80)																						
<p>New procurement office space at a lettable area 135 m² with parking bay: Department of Chief Prosecutor: National Prosecuting Authority.</p> <p>(NB: The below mentioned copies should accompany the tender documents on submission).</p> <ol style="list-style-type: none"> 1. Certified copies of shareholding certificate of BEE company. 2. Confirmation of shares of BEE company with Department of Trade and Industry. 3. Copy of Title Deeds of the property proving ownership or Mortgage by the BEE company. <p>This bid will be evaluated in terms of:</p> <p>90/10 point scoring system</p> <p>Preference: Price and quality/functionality</p> <p>Historically Disadvantaged Individuals (HDI)</p> <table border="0"> <tr> <td>Persons who had no franchise in the national elections before the 1983 and 1993 Constitutions</td> <td>5 points</td> <td>Price:</td> <td>70% (of 90)</td> </tr> <tr> <td>Who is a female</td> <td>3 points</td> <td>Quality/ Functionality:</td> <td>30% (of 90)</td> </tr> <tr> <td>Persons with disability</td> <td>2 points</td> <td></td> <td></td> </tr> <tr> <td>Other:</td> <td>points</td> <td></td> <td></td> </tr> <tr> <td>Total must equal:</td> <td>10 points</td> <td>Total must equal:</td> <td>100% (of 90)</td> </tr> </table> <p>No site inspection.</p> <p>Note: Documents will be sold at a non-refundable deposit of R100,00 CASH per set.</p> <p>Contact for bid information: Mr Jonathan Maraba or Ms Lucia Makgaleng, Tel. (015) 293-8071.</p> <p>General enquiries: Kgopa ER, (015) 291-6300</p>	Persons who had no franchise in the national elections before the 1983 and 1993 Constitutions	5 points	Price:	70% (of 90)	Who is a female	3 points	Quality/ Functionality:	30% (of 90)	Persons with disability	2 points			Other:	points			Total must equal:	10 points	Total must equal:	100% (of 90)	Polokwane	PLO7/70	2007-12-11	638	638
Persons who had no franchise in the national elections before the 1983 and 1993 Constitutions	5 points	Price:	70% (of 90)																						
Who is a female	3 points	Quality/ Functionality:	30% (of 90)																						
Persons with disability	2 points																								
Other:	points																								
Total must equal:	10 points	Total must equal:	100% (of 90)																						
<p>New procurement office space at a lettable area 272.50 m² with 10 parking bays: Department of Correctional Services:</p> <p>(NB: The below mentioned copies should accompany the tender documents on submission).</p> <ol style="list-style-type: none"> 1. Certified copies of shareholding certificate of BEE company. 2. Confirmation of shares of BEE company with Department of Trade and Industry. 3. Copy of Title Deeds of the property proving ownership or Mortgage by the BEE company. 	Polokwane	PLO7/71	2007-12-11	638	638																				

DESCRIPTION	REQUIRED AT	TENDER No.	DUE AT 11:00	TENDERS OBTAINABLE FROM	POST OR DELIVER TENDERS TO																				
				See Annexure 1, Page 53																					
<p>This bid will be evaluated in terms of:</p> <p>90/10 point scoring system</p> <p>Preference: Price and quality/functionality</p> <p>Historically Disadvantaged Individuals (HDI)</p> <table border="0"> <tr> <td>Persons who had no franchise in the national elections before the 1983 and 1993 Constitutions</td> <td>4 points</td> <td>Price:</td> <td>70% (of 90)</td> </tr> <tr> <td>Who is a female</td> <td>3 points</td> <td>Quality/ Functionality:</td> <td>30% (of 90)</td> </tr> <tr> <td>Persons with disability</td> <td>3 points</td> <td></td> <td></td> </tr> <tr> <td>Other:</td> <td>points</td> <td></td> <td></td> </tr> <tr> <td>Total must equal:</td> <td>10 points</td> <td>Total must equal:</td> <td>100% (of 90)</td> </tr> </table> <p>No site inspection. Note: Documents will be sold at a non-refundable deposit of R100,00 CASH per set. <i>Contact for bid information:</i> Mr Jonathan Maraba or Ms Lucia Makgaleng, Tel. (015) 293-8071. <i>General enquiries:</i> Kgopa ER, (015) 291-6300</p>	Persons who had no franchise in the national elections before the 1983 and 1993 Constitutions	4 points	Price:	70% (of 90)	Who is a female	3 points	Quality/ Functionality:	30% (of 90)	Persons with disability	3 points			Other:	points			Total must equal:	10 points	Total must equal:	100% (of 90)					
Persons who had no franchise in the national elections before the 1983 and 1993 Constitutions	4 points	Price:	70% (of 90)																						
Who is a female	3 points	Quality/ Functionality:	30% (of 90)																						
Persons with disability	3 points																								
Other:	points																								
Total must equal:	10 points	Total must equal:	100% (of 90)																						
<p>New procurement office space at a lettable area 115 m² with 1 parking bay: Department of Correctional Services: (NB: The below mentioned copies should accompany the tender documents on submission).</p> <ol style="list-style-type: none"> 1. Certified copies of shareholding certificate of BEE company. 2. Confirmation of shares of BEE company with Department of Trade and Industry. 3. Copy of Title Deeds of the property proving ownership or Mortgage by the BEE company. <p>This bid will be evaluated in terms of:</p> <p>90/10 point scoring system</p> <p>Preference: Price and quality/functionality</p> <p>Historically Disadvantaged Individuals (HDI)</p> <table border="0"> <tr> <td>Persons who had no franchise in the national elections before the 1983 and 1993 Constitutions</td> <td>10 points</td> <td>Price:</td> <td>70% (of 90)</td> </tr> <tr> <td>Who is a female</td> <td>5 points</td> <td>Quality/ Functionality:</td> <td>30% (of 90)</td> </tr> <tr> <td>Persons with disability</td> <td>5 points</td> <td></td> <td></td> </tr> <tr> <td>Other:</td> <td>points</td> <td></td> <td></td> </tr> <tr> <td>Total must equal:</td> <td>10 points</td> <td>Total must equal:</td> <td>100% (of 90)</td> </tr> </table> <p>No site inspection. Note: Documents will be sold at a non-refundable deposit of R50,00 CASH per set. <i>Contact for bid information:</i> Mr Jonathan Maraba or Ms Lucia Makgaleng, Tel. (015) 293-8071. <i>General enquiries:</i> Kgopa ER, (015) 291-6300</p>	Persons who had no franchise in the national elections before the 1983 and 1993 Constitutions	10 points	Price:	70% (of 90)	Who is a female	5 points	Quality/ Functionality:	30% (of 90)	Persons with disability	5 points			Other:	points			Total must equal:	10 points	Total must equal:	100% (of 90)	Thabazimbi	PLO7/72	2007-12-11	638	638
Persons who had no franchise in the national elections before the 1983 and 1993 Constitutions	10 points	Price:	70% (of 90)																						
Who is a female	5 points	Quality/ Functionality:	30% (of 90)																						
Persons with disability	5 points																								
Other:	points																								
Total must equal:	10 points	Total must equal:	100% (of 90)																						
<p>New procurement office space at a lettable area 110 m² with 1 parking bay: Department of Correctional Services: (NB: The below mentioned copies should accompany the tender documents on submission).</p> <ol style="list-style-type: none"> 1. Certified copies of shareholding certificate of BEE company. 2. Confirmation of shares of BEE company with Department of Trade and Industry. 3. Copy of Title Deeds of the property proving ownership or Mortgage by the BEE company. <p>This bid will be evaluated in terms of:</p> <p>90/10 point scoring system</p> <p>Preference: Price and quality/functionality</p> <p>Historically Disadvantaged Individuals (HDI)</p> <table border="0"> <tr> <td>Persons who had no franchise in the national elections before the 1983 and 1993 Constitutions</td> <td>10 points</td> <td>Price:</td> <td>70% (of 90)</td> </tr> <tr> <td>Who is a female</td> <td>5 points</td> <td>Quality/ Functionality:</td> <td>30% (of 90)</td> </tr> <tr> <td>Persons with disability</td> <td>5 points</td> <td></td> <td></td> </tr> <tr> <td>Other:</td> <td>points</td> <td></td> <td></td> </tr> <tr> <td>Total must equal:</td> <td>10 points</td> <td>Total must equal:</td> <td>100% (of 90)</td> </tr> </table>	Persons who had no franchise in the national elections before the 1983 and 1993 Constitutions	10 points	Price:	70% (of 90)	Who is a female	5 points	Quality/ Functionality:	30% (of 90)	Persons with disability	5 points			Other:	points			Total must equal:	10 points	Total must equal:	100% (of 90)	Bela-Bela	PLO7/73	2007-12-11	638	638
Persons who had no franchise in the national elections before the 1983 and 1993 Constitutions	10 points	Price:	70% (of 90)																						
Who is a female	5 points	Quality/ Functionality:	30% (of 90)																						
Persons with disability	5 points																								
Other:	points																								
Total must equal:	10 points	Total must equal:	100% (of 90)																						

DESCRIPTION	REQUIRED AT	TENDER No.	DUE AT 11:00	TENDERS OBTAINABLE FROM	POST OR DELIVER TENDERS TO
				See Annexure 1, Page 53	
No site inspection. Note: Documents will be sold at a non-refundable deposit of R100,00 CASH per set. <i>Contact for bid information:</i> Mr Jonathan Maraba or Ms Lucia Makgaleng, Tel. (015) 293-8071. <i>General enquiries:</i> Kgopa ER, (015) 291-6300					

SUPPLIES: CLOTHING/TEXTILES

Correction notice of tender No. HK 9/2007 for the supply and delivery of socks for offenders, was incorrectly advertised as HK 7/2007 in the tender bulletin, dated 9 November 2007. <i>Contact person:</i> AM Simmons, Tel. (012) 305-8037/ Fax (012) 323-5621	Department of Correctional Services: Witbank Management Area	HK 9/2007	2007-12-10	184	184
Manufacture, supply and delivery of bullet resistant vests. <i>Enquiries:</i> Pac Kola, Tel. (012) 841-7679	South African Police Service	19/1/9/1/115TT(07)	2008-01-24	606	606
Manufacture, supply and delivery of concealed bullet resistant vests. <i>Enquiries:</i> Pac Kola, Tel. (012) 841-7679	South African Police Service	Q19/1/9/1/213TT(06)	2008-01-24	606	606

SUPPLIES: FURNITURE

Sport & Recreation SA (SRSA) hereby invites tenders for supply and delivery of 20 desks and 20 roller door cupboards in accordance with the attached specification. <i>Tender:</i> Ms K.J. Tselane, (012) 304-5251 <i>Technical:</i> Charl Durand, (012) 304-5011	No. 66 Regent Place, cnr Queen and Vermeulen Streets, Pretoria	1/8/5/2 (033/07)	2007-12-29	780	780
---	--	------------------	------------	------------	------------

Range	Description	Legs/frame Handles	Edging	Veneer/ Laminate	Qty
Cope 2000	Rollerdoor Pedenza	Basalt	Basalt PVC	Birn Laminate	5
Cope 2000	1150x1150x650 Core top		Basalt PVC	Birn Laminate	5
Cope 2000	650x650x650 Rect. Top		Basalt PVC	Birn Laminate	5
Cope 2000	1800x300 Visitors Ext Top		Basalt PVC	Birn Laminate	5
Cope 2000	950x745 D End		Basalt PVC	Birn Laminate	5
Cope 2000	Pole Legs	Basalt			5
Cope 2000	Joining Kit	Basalt			1
	Consisting of 1x Linking Bracket				
	7x Variable Connecting Brackets				

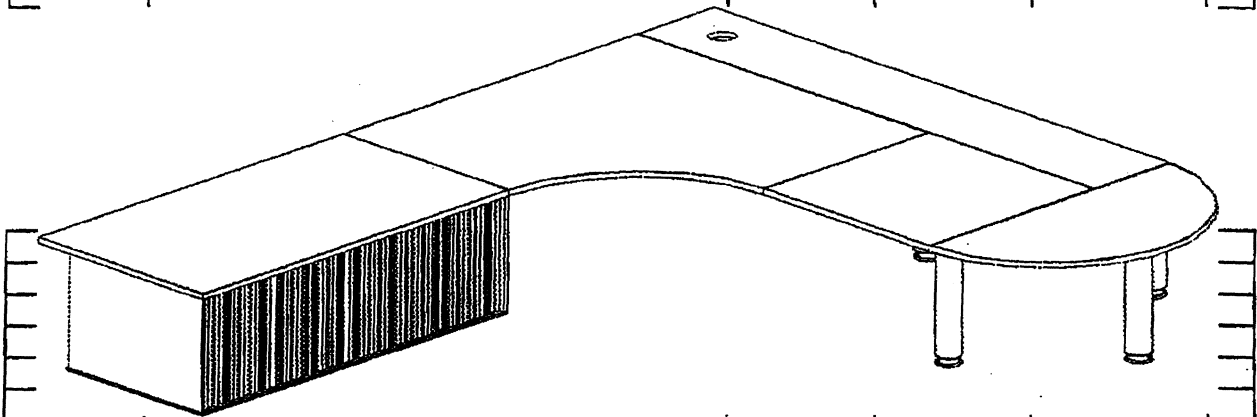

Cope 2000	Desk High Pedestal	Basalt	Basalt PVC	Birn Laminate	15
Cope 2000	1150x1150x650 Core Top		Basalt PVC	Birn Laminate	15
Cope 2000	650x650x650 Rect. Top		Basalt PVC	Birn Laminate	30
Cope 2000	650x325 D End		Basalt PVC	Birn Laminate	15
Cope 2000	Pole Legs	Basalt			60
Cope 2000	Joining Kit	Basalt			15
	Consisting of 6 Variable Brackets				

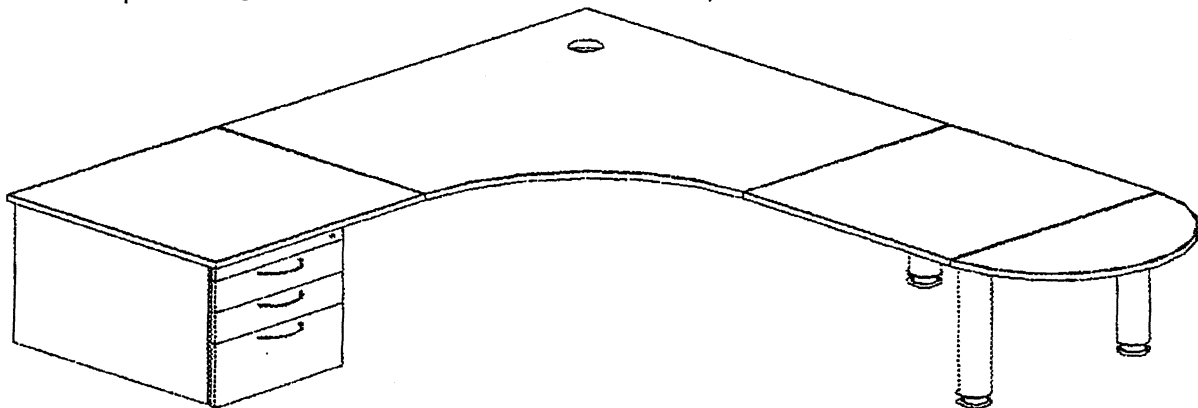

Cope 2000 Rollerdoor Cupboard
(including 3 shelves)

Basalt Basalt PVC Birn Laminate 20

DESCRIPTION	REQUIRED AT	TENDER No.	DUE AT 11:00	TENDERS OBTAINABLE FROM	POST OR DELIVER TENDERS TO
				See Annexure 1, Page 53	

SUPPLIES: GENERAL

Supply and delivery of an aircraft tow tractor in according with SAPS specification 2509/2007. <i>Contact person:</i> Mrs Van Wyngaardt, Tel. (012) 841-7459	South African Police Service, Gauteng Province, Wonderboom Air Wing, Rebeka Street, SAPS College, Pretoria West Air Wing	Q19/1/9/1/114 TV (07)	2008-01-31	110	110
Four (4) Combi—Cooking Steamer Units. <i>Enquiries:</i> Mrs M. Visser, Tel. (021) 938-5605	Tygerberg Hospital	TBH 214/2007	2007-12-21	325	325
Supply and delivery of trunk and wardrobes. Bid documents can be collected at Centre Procurement Service Centre. Alternatively a self-addressed and stamped envelope R13,40 (E3 size) can be sent to this Centre. <i>Enquiries:</i> Warrant Officer Tebogo Mooka, Tel. (012) 684-2633	2 Field Engineer Regiment, Bethlehem	CPSC/B/G/559/07	2007-12-03	371A	371A
Supply and delivery of various type of sports balls	Department of Correctional Services (National)	HK14/2007	2008-01-16	184	184
Supply and delivery of one (1) 3.3 m ³ front end loader for Directorate Construction. <i>For technical information: Contact person:</i> Mr J.D. Baker, Tel. (012) 336-8445/082 807 6622	Limpopo (De Hoop Dam)	W 9758	2008-01-10	95B	95B
Supply and delivery of two (2) hydraulic mobile cranes for Directorate Construction. <i>For technical information: Contact person:</i> Mr J.D. Baker, Tel. (012) 336-8445/082 807 6622	Limpopo (Levubu)	W 9761	2008-01-10	95B	95B
Invitation to prospective bidders for the procurement of a patrol boat system for the operational boat squadron of the SA Navy to be deployed outside the borders of the RSA. Compulsory briefing session will be held on 3 December 2007 at 11h00. Bidders to be seated at 11h00, as doors will be locked at 11h00. Briefing session will be held at Simonstown Procurement Service Centre, Conference Room, Arsenal Road, Simonstown, Cape Town. Note: Bid documents can be collected at Simonstown Procurement Service Centre, Arsenal Road, Simonstown from 23 November 2007. Failure to attend compulsory briefing session will invalidate the bid. Only bidders who attend the briefing session, bids will be considered. No late-comers will be accommodated. <i>Contact person:</i> Captain H.N. Marais, Tel. (021) 787-4320 during office hours only	GSB Simonstown	SPSC-B-072-2007	2007-12-18	360	360
Supply and delivery of Batons Tonfa to the SAPS in accordance with Dept. Spec. <i>Enquiries:</i> Mr Billy Mothula/Ms Jacobeth Masemola, Tel. (012) 841-7459/7551. <i>E-mail:</i> vwynngaardta@saps.org.za	SCM: Divisional Commissioner, 117 Cresswell Road, Silverton, Pretoria	19/1/9/1/31 TD(07)	2007-12-13	110	110

SUPPLIES: MEDICAL

A radiographic/fluoroscopic unit mobile C—Arm system for use in the Cardiology Pace-maker Theatre. <i>Enquiries:</i> Mrs M. Visser, Tel. (021) 938-5605	Tygerberg Hospital	TBH215/2007	2007-12-21	325	325
--	--------------------	-------------	------------	------------	------------

SUPPLIES: PERISHABLE PROVISIONS

Supply and delivery of perishable provisions to Grootvlei Management Area: Period 1 April 2008 to 31 March 2009	Grootvlei Management Area	GVR 1/2007	2008-01-18	178	178
Supply and delivery of perishable provisions to Kroonstad Management Area: Period 1 April 2008 to 31 March 2009	Kroonstad	KST 3/2007	2008-01-16	193	193

DESCRIPTION	REQUIRED AT	TENDER No.	DUE AT 11:00	TENDERS OBTAINABLE FROM	POST OR DELIVER TENDERS TO
				See Annexure 1, Page 53	
Supply and delivery of perishable provisions to Bethlehem Correctional Centre: Period 1 April 2008 to 31 March 2009	Bethlehem	BHM 01/2007	2008-01-16	145	145
Supply and delivery of perishable provisions to Harrismith Correctional Centre: Period 1 April 2008 to 31 March 2009	Harrismith	HARCC 01/2007	2008-01-16	179	179
Supply and delivery of perishable provisions to Ventersburg Correctional Centre: Period 1 April 2008 to 31 March 2009	Ventersburg	VEN 01/2007	2008-01-16	242	242
Supply and delivery of perishable provisions to Hennenman Correctional Centre: Period 1 April 2008 to 31 March 2009	Hennenman	HEN 01/2007	2008-01-16	183	183
Supply and delivery of perishable provisions to Odendaalsrus Correctional Centre: Period 1 April 2008 to 31 March 2009	Odendaalsrus	ODI 01/2007	2008-01-16	217	217
Supply and delivery of perishable provisions to Virginia Correctional Centre: Period 1 April 2008 to 31 March 2009	Virginia	VIR 01/2007	2008-01-16	246	246
Extending of closing date: Supply and delivery of highly perishable provisions: Period 1 April 2008 to 31 March 2009	Empangeni Correctional Centre	KZN 05/2007	2008-01-16	362	362
Extending of closing date: Supply and delivery of highly perishable provisions: Period 1 April 2008 to 31 March 2009	Kokstad Correctional Centre	KZN 06/2007	2008-01-16	362	362
Extending of closing date: Supply and delivery of highly perishable provisions: Period 1 April 2008 to 31 March 2009	Ncome Correctional Centre	KZN 07/2007	2008-01-16	362	362
Extending of closing date: Supply and delivery of highly perishable provisions: Period 1 April 2008 to 31 March 2009	Glencoe Correctional Centre	KZN 08/2007	2008-01-16	362	362
Extending of closing date: Supply and delivery of highly perishable provisions: Period 1 April 2008 to 31 March 2009	Ladysmith Correctional Centre	KZN 09/2007	2008-01-16	362	362
Extending of closing date: Supply and delivery of highly perishable provisions: Period 1 April 2008 to 31 March 2009	Eshowe Correctional Centre	KZN 10/2007	2008-01-16	362	362
Extending of closing date: Supply and delivery of highly perishable provisions: Period 1 April 2008 to 31 March 2009	Stanger Correctional Centre	KZN 11/2007	2008-01-16	362	362
Extending of closing date: Supply and delivery of highly perishable provisions: Period 1 April 2008 to 31 March 2009	Port Shepstone Correctional Centre	KZN 12/2007	2008-01-16	362	362

SUPPLIES: STATIONERY/PRINTING

Supply, delivery and printing of SAPS Journal for a period of two (2) years. <i>Enquiries: Mrs Van Wyngaardt, Tel. (012) 841-7459</i>	SAPS: Communication & Liaison Services	Q19/1/9/1/108TS(07)	2007-12-14	90	90
--	---	---------------------	------------	----	----

SERVICES: BUILDING

<p>Wolmaransstad Magistrate: Repairs and renovations to State Houses No. 56 and 23 including replacement/repair of fence at N. 23.</p> <p><i>CIDB Contractor grading designation required:</i></p> <p>It is estimated that tenderers should have a CIDB contractor grading designation of 3 GB or 3 GB or higher.</p> <p>It is estimated that potentially emerging enterprises should have a CIDB contractor grading designation of 2 GB PE or 2 GB PE.</p> <p>This tender will be evaluated commensurate with the applicable scoring model at the time of evaluation.</p>	Wolmaransstad	MMB 07/065	2007-12-19	324	324
--	---------------	------------	------------	-----	-----

DESCRIPTION	REQUIRED AT	TENDER No.	DUE AT 11:00	TENDERS OBTAINABLE FROM	POST OR DELIVER TENDERS TO
				See Annexure 1, Page 53	
<p>The following criteria is applicable:</p> <p>Preference:</p> <p>1. Historically Disadvantaged Individuals (HDI)</p> <p>(a) Persons who had no franchise in national elections before the 1983 and 1993 Constitutions 7 points</p> <p>(b) Who is a female 2 points</p> <p>(c) Persons with disability 1 point</p> <p>2. Other specific goals (according to the PPPFA)</p> <p>(a) Contract participation goal by awarding contracts to targeted enterprises points</p> <p>(b) points</p> <p>(c) points</p> <p>Total must equal 10 or 20 points points</p> <p>Price and quality weighting:</p> <p>Quality: 0% Price: 100%</p> <p>Total must equal 100%</p> <p>A compulsory site inspection on the 04/12/2007 at 11:00. Prospective tenderers to meet at Wolmaransstad Magistrate's Office.</p> <p>Note: Documents will be sold at a non-refundable deposit of R100,00 CASH per set.</p> <p>Contact for tender information: Bakang Sedumedi/Badisa Motlathledi, (018) 384-9331 Ext. 2308/2303.</p> <p>General enquiries: Ms B.P. Nkoe, (018) 384-9331 Ext. 2220</p>					
<p>Pretoria: Union Buildings: Refurbishment of office accommodation: West Wing: Lower Ground Floor Level: Glass ceilings (pre-qualified procedure).</p> <p><i>CIDB Contractor grading designation required:</i></p> <p>It is estimated that tenderers should have a CIDB contractor grading designation of 3 SG or 3 SG or higher.</p> <p>It is estimated that potentially emerging enterprises should have a CIDB contractor grading designation of 2 SG PE or 2 SG PE.</p> <p>This tender will be evaluated commensurate with the applicable scoring model at the time of evaluation.</p> <p>The following criteria is applicable:</p> <p>Preference:</p> <p>1. Historically Disadvantaged Individuals (HDI)</p> <p>(a) Persons who had no franchise in national elections before the 1983 and 1993 Constitutions 5 points</p> <p>(b) Who is a female 4 points</p> <p>(c) Persons with disability 1 point</p> <p>2. Other specific goals (according to the PPPFA)</p> <p>(a) Contract participation goal by awarding contracts to targeted enterprises 0 points</p> <p>(b) points</p> <p>(c) points</p> <p>Total must equal 10 or 20 points 10 points</p> <p>Price and quality weighting:</p> <p>Quality: 40% Price: 60%</p> <p>Total must equal 100%</p> <p>No site inspection.</p> <p>Note: Documents will be sold at a non-refundable deposit of R50,00 CASH per set.</p> <p>Contact for tender information: Ms S. Ndlovu, Tel. (012) 310-5125.</p> <p>General enquiries: Project Manager: Ms S.O'Neil, Tel. (012) 310-5110/Cell: 083 677 4883</p>	Pretoria	PT07/091	2007-12-04	63	63
SERVICES: FUNCTIONAL (INCLUDING CLEANING AND SECURITY SERVICES)					
<p>Pretoria: Union Buildings: Upgrading of Access Control, Security Monitoring and Closed Circuit Television Surveillance System (pre-qualified procedure)</p> <p><i>CIDB Contractor grading designation required:</i></p> <p>It is estimated that tenderers should have a CIDB contractor grading designation of 6 SA or 6 SA or higher.</p> <p>It is estimated that potentially emerging enterprises should have a CIDB contractor grading designation of 5 SA PE or 5 SA PE.</p> <p>This tender will be evaluated commensurate with the applicable scoring model at the time of evaluation.</p>	Pretoria	PT07/092	2007-12-04	63	63

DESCRIPTION	REQUIRED AT	TENDER No.	DUE AT 11:00	TENDERS OBTAINABLE FROM	POST OR DELIVER TENDERS TO
				See Annexure 1, Page 53	
<p>The following criteria is applicable:</p> <p>Preference:</p> <p>1. Historically Disadvantaged Individuals (HDI)</p> <p>(a) Persons who had no franchise in national elections before the 1983 and 1993 Constitutions 5 points</p> <p>(b) Who is a female 4 points</p> <p>(c) Persons with disability 1 point</p> <p>2. Other specific goals (according to the PPPFA)</p> <p>(a) Contract participation goal by awarding contracts to targeted enterprises 0 points</p> <p>(b) _____ points</p> <p>(c) _____ points</p> <p>Total must equal 10 or 20 points 10 points</p> <p>Price and quality weighting:</p> <p>Quality: 40% Price: 60%</p> <p>Total must equal 100%</p> <p>No site inspection.</p> <p>Note: Documents will be sold at a non-refundable deposit of R50,00 CASH per set.</p> <p>Contact for tender information: Ms S. Ndlovu, Tel. (012) 310-5125.</p> <p>General enquiries: Project Manager: Ms S.O'Neil, Tel. (012) 310-5110/Cell: 083 677 4883</p>					
<p>Providing of security services at access control points plus patrolling of premises at Middel Letaba (between Giyani and Elim) for the duration of 24 (twenty four) months. A compulsory briefing session is to be held: <i>Venue:</i> Middel-Letaba. <i>Date:</i> 11/12/2007. <i>Time:</i> 14:00. <i>For technical information: Contact person:</i> Mr R. Baloyi, Tel. (015) 307-8666/082 907 8249</p>	Limpopo	W 9662	2007-01-10	749	749
<p>Providing of security services at access control points plus patrolling of premises at Levhuvu-Letaba Proto-CMA (next to Tzaneen Dam) for the duration of 24 (twenty four) months. A compulsory briefing session is to be held: <i>Venue:</i> Levhuvu-Letaba Proto-CMA. <i>Date:</i> 10/12/2007. <i>Time:</i> 11:00. <i>For technical information: Contact person:</i> Mr R. Baloyi, Tel. (015) 307-8666/082 907 8249</p>	Limpopo	W 9663	2007-01-10	749	749
<p>Providing of security services at access control points plus patrolling of premises at Nandoni Dam (between Malamulele and Thohoyandou) for the duration of 24 (twenty four) months. A compulsory briefing session is to be held: <i>Venue:</i> Nandoni Dam. <i>Date:</i> 12/12/2007. <i>Time:</i> 14:00. <i>For technical information: Contact person:</i> Mr R. Baloyi, Tel. (015) 307-8666/082 907 8249</p>	Limpopo	W 9664	2007-01-10	749	749
<p>Providing of security services at access control points plus patrolling of premises at Glen Alpine Dam (between Bokgom and Stalloop) for the duration of 24 (twenty four) months. A compulsory briefing session is to be held: <i>Venue:</i> Glen Alpine Dam. <i>Date:</i> 14/12/2007. <i>Time:</i> 13:00. <i>For technical information: Contact person:</i> Mr R. Baloyi, Tel. (015) 307-8666/082 907 8249</p>	Limpopo	W 9665	2007-01-10	749	749
<p>Providing of security services at access control points plus patrolling of premises at Albasini Dam (between Elim and Thohoyandou) for the duration of 24 (twenty four) months. A compulsory briefing session is to be held: <i>Venue:</i> Albasini Dam. <i>Date:</i> 12/12/2007. <i>Time:</i> 12:00. <i>For technical information: Contact person:</i> Mr R. Baloyi, Tel. (015) 307-8666/082 907 8249</p>	Limpopo	W 9666	2007-01-10	749	749
<p>Providing of security services at access control points plus patrolling of premises at Tzaneen Area Office (Voortrekker Street, Tzaneen Dam) for the duration of 24 (twenty four) months. A compulsory briefing session is to be held: <i>Venue:</i> Tzaneen Area Office, Voortrekker Street. <i>Date:</i> 10/12/2007. <i>Time:</i> 10:00. <i>For technical information: Contact person:</i> Mr R. Baloyi, Tel. (015) 307-8666/082 907 8249</p>	Limpopo	W 9667	2007-01-10	95B	95B

DESCRIPTION	REQUIRED AT	TENDER No.	DUE AT 11:00	TENDERS OBTAINABLE FROM	POST OR DELIVER TENDERS TO
				See Annexure 1, Page 53	
The rendering and maintenance of garden services at Roodeplaats Training Centre for a period of 12 months. A compulsory briefing session is to be held: <i>Venue:</i> Roodeplaats Traing Centre. <i>Date:</i> 12/12/2007. <i>Time:</i> 11:00. <i>For technical information: Contact person:</i> Ms Gugu Mtolo, Tel. (012) 808-9566/082 808 2700	Pretoria	W 9703	2007-01-10	95B	95B

SERVICES: GENERAL

<p>Pretoria: Union Buildings: Refurbishment of office accommodation West Wing: Lower Ground Floor Level: Fire installation (Pre-qualified procedure).</p> <p><i>CIDB Contractor grading designation required:</i> It is estimated that tenderers should have a CIDB contractor grading designation of 2 SF or 2 SF or higher. It is estimated that potentially emerging enterprises should have a CIDB contractor grading designation of 1 SF PE or 1 SF PE.</p> <p>This tender will be evaluated commensurate with the applicable scoring model at the time of evaluation.</p> <p>The following criteria is applicable:</p> <p>Preference:</p> <table border="1"> <tr> <td colspan="2">1. Historically Disadvantaged Individuals (HDI)</td> </tr> <tr> <td>(a) Persons who had no franchise in national elections before the 1983 and 1993 Constitutions</td> <td>5 points</td> </tr> <tr> <td>(b) Who is a female</td> <td>4 points</td> </tr> <tr> <td>(c) Persons with disability</td> <td>1 point</td> </tr> <tr> <td colspan="2">2. Other specific goals (according to the PPPFA)</td> </tr> <tr> <td>(a) Contract participation goal by awarding contracts to targeted enterprises</td> <td>0 points</td> </tr> <tr> <td>(b)</td> <td>points</td> </tr> <tr> <td>(c)</td> <td>points</td> </tr> <tr> <td>Total must equal 10 or 20 points</td> <td>10 points</td> </tr> <tr> <td colspan="2">Price and quality weighting:</td> </tr> <tr> <td>Quality: 40%</td> <td>Price: 60%</td> </tr> <tr> <td colspan="2">Total must equal 100%</td> </tr> </table> <p>No site inspection.</p> <p>Note: Documents will be sold at a non-refundable deposit of R50,00 CASH per set.</p> <p><i>Contact for tender information:</i> Ms S. Ndlovu, Tel. (012) 310-5125.</p> <p><i>General enquiries: Project Manager:</i> Ms S.O'Neil, Tel. (012) 310-5110/Cell: 083 677 4883</p>	1. Historically Disadvantaged Individuals (HDI)		(a) Persons who had no franchise in national elections before the 1983 and 1993 Constitutions	5 points	(b) Who is a female	4 points	(c) Persons with disability	1 point	2. Other specific goals (according to the PPPFA)		(a) Contract participation goal by awarding contracts to targeted enterprises	0 points	(b)	points	(c)	points	Total must equal 10 or 20 points	10 points	Price and quality weighting:		Quality: 40%	Price: 60%	Total must equal 100%		Pretoria	PT07/090	2007-12-04	63	63
1. Historically Disadvantaged Individuals (HDI)																													
(a) Persons who had no franchise in national elections before the 1983 and 1993 Constitutions	5 points																												
(b) Who is a female	4 points																												
(c) Persons with disability	1 point																												
2. Other specific goals (according to the PPPFA)																													
(a) Contract participation goal by awarding contracts to targeted enterprises	0 points																												
(b)	points																												
(c)	points																												
Total must equal 10 or 20 points	10 points																												
Price and quality weighting:																													
Quality: 40%	Price: 60%																												
Total must equal 100%																													
Distribution of the SAPS Journal for a period of two (2) years. <i>Enquiries:</i> Mrs Van Wyngaardt, Tel. (012) 841-7459	SAPS: Communication & Liaison Services	Q19/1/9/1/112TS(07)	2007-12-14	90	90																								

SERVICES: MECHANICAL

<p>Preventative maintenance and necessary repairs to air-conditioning and refrigeration equipment, plus any other repairs that are related to all mechanical services within the various Provincial Buildings, outside the Central Business District for a period of 24 months: Cape Town.</p> <p><i>Designated Grading 3ME or higher.</i></p> <p><i>Technical information:</i> Mr P Moonsamy, 083 647 4055. A non-refundable deposit of R50,00 per set is payable. <i>Further enquiries:</i> Jody Burricks, (021) 483-5240, Fax (021) 483-2488</p>	Cape Town	S124/07	2008-01-22	300	352
---	-----------	---------	------------	-----	-----

SERVICES: PROFESSIONAL

Training of 100 moderators in all 9 provinces	No. 2 Bradford Road, Bedfordview, 2047	ETQA03/07	2007-12-14	709	709
Training of 100 assessors in all nine provinces	No. 2 Bradford Road, Bedfordview	ETQA03/07	2007-12-14	709	709

DESCRIPTION	REQUIRED AT	TENDER No.	DUE AT 11:00	TENDERS OBTAINABLE FROM	POST OR DELIVER TENDERS TO
				See Annexure 1, Page 53	
Bidders are hereby invited to submit proposals for Events Management Company to arrange a one day conference 'Building a Socially Inclusive Gauteng Region'. RFP documents are obtainable at Imbumba House, 75 Fox Street, Marshalltown, Ground Floor, Tender issue desk. Re: Tender Issue: Leonard Billings, (011) 689-6416. Enquiries: Contact: Sheriff Lecholo, at (011) 689-8320 and Khwezi Finini, at (011) 355-7978	Department of Social Development	GT/GDSD/154/2007	2007-12-14	323	323
Development of the Business Management System (BMS) for the FET Colleges for the Department of Education. A non-compulsory briefing session: Date: 30/11/2007. Venue: Sita Auditorium Erasmuskloof. Bid validity period: 90 days (commencing from the RFB closing date). Bidders should ensure that bids are delivered in time to the correct address. If the bid is late, it will not be accepted for consideration. The bid box is generally accessible 24 hours a day, 7 days a week	SITA	RFB614/2007	2007-12-21	616	616
The appointment of a contractor to assist the Department of Agriculture with public participation, awareness and community empowerment for a period of eighteen (18) months. A compulsory briefing session will be held on 5 December 2007 at 10:30 at the Dirk Immelman Hall, 2nd Floor, Delpen Building, cnr Annie Botha and Union Streets, Pretoria. Contact person: Lydia Bosoga, Tel. (012) 319-7656	Pretoria	4.4.12.4/46/07	2007-12-21	115	115
Banking Services. The Legal Aid Board (LAB) is a public entity established by the Legal Aid Act (Act 22 of 1969) to make legal assistance available to indigent people as contemplated in the Constitution. LAB is managed within the framework of the Public Finance Management Act (Act 1 of 1999). Its main objective is the provision of legal assistance to the indigent and poor. The Legal Aid Board invites duly registered banking institutions to provide the LAB with a full range of banking services for a period of 3 years. Tender documents will be available from Tuesday, 27 November 2007 at Legal Aid House, 29 De Beer Street, Braamfontein, Johannesburg. Bidders should take note that LAB reserves the right to negotiate terms and conditions after the selection of the successful tender. Tenders must be deposited in the tender box on the Ground Floor, Legal Aid House, 29 De Beer Street, Braamfontein, Johannesburg, by no later than 11h00 on Friday, 14 December 2007. NB: No faxed, e-mailed or late tenders will be accepted. Tender enquiries may be directed to: Dumisani Dlamini/John Bopape, Tel. (011) 877-2000	Legal Aid Board, Private Bag X76, Braamfontein, 2017	15/2007	2007-12-14	528	528
Bid VA49/317: To appoint an external service provider for the terms of reference for the evaluation and reporting on the advance tranche payments made to municipalities to implement approved project linked subsidies. Enquiries: M. Hitge/Ms A.Y. Venter, Tel. (012) 421-1355/1307	Pretoria	VA49/317	2007-12-14	71A	71A
Appointment of a service provider to provide ERP production server solution for SASSA. Enquiries: Godfrey Twala, Tel. (012) 400-2167	Head Office	RFQ 007/ICT	2007-12-03	731	731
Withdrawal of tender: Nationwide supply, delivery and installation of furniture and fittings at SASSA. Enquiries: Godfrey Twala, Tel. (012) 400-2167		SASSA 21/06/CS			
Approval of an open tender process to procure the services of researchers/consultants to conduct a research—The impact of intellectual property (IP) System on Education, Health, Research, Innovation and Development, Franchising, Information Sharing, Telecommunications and ICT, Technology Transfer, Consumer Protection and Access to Knowledge in South Africa	Department of Trade and Industry	DTI 19/07-08	2007-12-14	419	419

DESCRIPTION	REQUIRED AT	TENDER No.	DUE AT 11:00	TENDERS OBTAINABLE FROM	POST OR DELIVER TENDERS TO
				See Annexure 1, Page 53	
Awareness and impact assessment of the communication initiatives on Second Economic Programmes. <i>Technical enquiries:</i> Mrs Ntombifuthi Gumede, (012) 314-2226 or Dr Marietjie Strydom, Tel. (012) 314-2174 <i>Bid procedures:</i> G Storey & M Moreroa, Tel. (012) 314-2464, Tel. (012) 314-2246, Fax (012) 323-3831 <i>Further enquiries:</i> P Menwe, Tel. (012) 341-2855, E-mail: Phenyo@gcis.gov.za	G.C.I.S.	GCIS 016/2007/2008	2007-12-14	20	20
Bid to appoint a service provider for the upgrading of security system at Durban Labour Centre. A compulsory briefing and site inspection will be held on 28 November 2007 at 10:00–11:00 am in Room 317, at Durban Labour Centre, Masoni Groove Building, Durban. <i>Contact person:</i> Martin Zulu @ (031) 336-1502	Durban Labour Centre	LAB 15/2007	2007-12-07	78	78
Appointment of professional service provider to provide financial management, programme management and other ancillary services for the implementation of a water sector support programme, Masibambane III, under the Theme, Water for Growth and Development. <i>A compulsory briefing session will be held as follows: Date: 6 December 2007. Time: 12h00. Venue: 173 Schoeman Street (Emanzini Building, Room G18).</i> All bidders must have tender documents during the briefing session and be familiar with them. <i>For technical information: Contact person: Mr T Malkiewicz/ Mr K Pelpola, Tel. (012) 336-8608/8798</i>	DWAF	WP 9552	2008-01-15	95A	95A
Appointment of professional service provider to undertake regulatory performance measurement system. <i>For technical information: Contact person: MSN Moshidi, Tel. (012) 336-6614</i>	DWAF	WP 9698	2008-01-15	95A	95A
Invitation of bids for the auditing of monthly fuel price changes. A compulsory briefing session will be held on 6/12/2007 at 10h00 at corner Andries and Visagie Streets. Will be based on 80/20 principle	Department of Minerals and Energy	ME-657	2008-01-07	11	11
Invitation of bids for the appointment of an earthworks contractor to undertake the rehabilitation of the derelict & ownerless asbestos mine in the Northern Cape Province (Strelley Mine) A compulsory site inspection will be held on 11/12/2007 in the Northern Cape Province. Evaluation will be based on 90/10 principle	Department of Minerals and Energy	ME-658	2008-01-07	11	11
The development and implementation of branding Gauteng Implementation Strategy, including Media Products and communication campaigns to give effect to the Branding Strategic Framework. RFP documents are obtainable at Imbumba House, 75 Fox Street, Marshalltown, Ground Floor, Tender Issue Desk. <i>Briefing session: 30/11/2007. Time: 9.00. Venue: Imbumba House, 75 Fox Street, Ground Floor, Auditorium.</i> <i>For specification contact: Israel Mogale, Tel. (011) 355-6281. Enquiries: Contact: Gerrie Harmse, (011) 689-8086</i>	Office of the Premier	GT/OoP/158/2007	2007-12-14	323	323
Universal Service and Access Agency of South Africa (USAASA) requires applications from interested consultancies to supply ICT kiosk system that will be used in community ICT access centres in the under-serviced areas. Compulsory briefing session on 30 November 2007 at 12:00 noon. <i>Contact person: Mr Alex Ngqwebo/Mr Thabo Makenete, Tel. (011) 564-1600</i>	USAASA, 21 Thornhill Park, Bekker Street, Midrand; P.O. Box 12601, Vorma Valley, 1686	USAASA 06/2007-2008	2007-12-14	856	856
Universal Service and Access Agency of South Africa (USAASA) requires applications from interested consultancies to supply an ICT access centre survey/statistical information management system for monitoring and evaluation. Compulsory briefing session on 30 November 2007 at 10:00. <i>Contact person: Mr Alex Ngqwebo/Mr Thabo Makenete, Tel. (011) 564-1600</i>	USAASA, 21 Thornhill Park, Bekker Street, Midrand; P.O. Box 12601, Vorma Valley, 1686	USAASA 07/2007-2008	2007-12-14	856	856

DESCRIPTION	REQUIRED AT	TENDER No.	DUE AT 11:00	TENDERS OBTAINABLE FROM	POST OR DELIVER TENDERS TO
				See Annexure 1, Page 53	
Appointment of a service provider to design a Gender Policy Framework for the Department of Social Development over a period of 12 months	Department of Social Development, Pretoria	SD26/2007	2007-12-20	116	116
<p>Re-advertisement of tender: The Department of Justice and Constitutional Development hereby invites experienced research/Project management consultants to submit proposals on the Review of Criminal Justice System to be conducted over a 12 month period: The bid documents can be collected from the reception on 1st Floor, Momentum Building, corner of Pretorius and Prinsloo Streets, Pretoria. Collection time is between 07:30 and 16:00, during working days. The documentation can be collected from Friday, 23 November 2007. Enquiries can be directed to: Khathu Raphunga, Tel. (012) 315-1733. Fax: 086 688 6619. E-mail: kraphunga@justice.gov.za</p>	Department of Justice and Constitutional Development	RFP 2007 04B	2007-12-06	854	854
<p>The Department of Justice and Constitutional Development hereby invite interested parties to submit bid in response to the following tender: Provision of Transcription Services for the Limpopo Region. The bid documents can be collected from the reception on 1st Floor, Momentum Building, corner of Pretorius and Prinsloo Streets, Pretoria. Collection time is between 07:30 and 16:00, during working days. The documentation can be collected from Friday, 23 November 2007. Enquiries can be directed to: Khathu Raphunga, Tel. (012) 315-1733. Fax: 086 688 6619. E-mail: kraphunga@justice.gov.za</p>	Department of Justice and Constitutional Development	RFB 2007 30	2007-12-14	854	854
<p>Cancellation of bid: Appointment of professional service provider to undertake DWAF Climate/Consumer Satisfaction Survey. For technical information: Contact person: Ms L Makhanya, Tel. (012) 336-7404</p>	DWAF	W 9731	2007-12-18	95A	95A
<p>Correction notice of tender (Tender Number): Tourism KwaZulu-Natal (TKZN) invites service providers to conduct a feasibility study for the Border Cave Project, near Ingwavuma. This project has the potential to develop a heritage related tourism products, which will sufficiently act as a catalyst to draw tourists into the area and increase the sustainability of the project. It is important that the feasibility study displays the project's financial viability and ability to generate sufficient funds to generate revenues in order for it to be financially viable and sustainable. A compulsory briefing session will be held at Suite 303, 3rd Floor, Tourist Junction, 160 Pine Street, Durban, 4000 on the 22 November 2007 at 10h00. A non-refundable deposit of R50,00 is payable on obtaining of bidding documents. Enquiries: Ms HP Madondo, Tel. (031) 366-7501</p>	Tourism KwaZulu-Natal, Suite 303, 3rd Floor Tourism Junction, 160 Pine Street, Durban, 4000	04/11/2007	12:00	741	741
<p>Bidders are hereby invited to submit proposals for: Implementation of a Product Development and Market Access Programme for Gauteng Based Craft Enterprises and Individuals RFP documents are obtainable at Imbumba House, 75 Fox Street, Marshalltown, Ground Floor. Tender briefing session will be held at: 75 Fox Street, Johannesburg, Imbumba House, Ground Floor, Auditorium. Date: 30 November 2007. Time: 11h00. Enquiries: Contact: J. Makwala, (011) 689-6970. Technical enquiry: A. Lebethe, (011) 355-2500</p>	Department of Sports, Arts, Culture and Recreation	GT/ GDSRAC/ 159/2007	2007-12-07	323	323

DESCRIPTION	REQUIRED AT	TENDER No.	DUE AT 11:00	TENDERS OBTAINABLE FROM	POST OR DELIVER TENDERS TO
				See Annexure 1, Page 53	
Bidders are hereby invited to submit proposals for: Implementation of Provincial Plan to Support the Grade 12 learners for Gauteng Department of Education. RFP documents are obtainable at Imbumba House, 75 Fox Street, Marshalltown, Ground Floor, Tender issue desk. <i>Briefing session:</i> 30 November 2007, at 75 Fox Street, Marshalltown (Auditorium), 12:00–13:00. <i>Enquiries: Contact:</i> W. de Buys, (011) 689-6880. <i>Technical enquiries:</i> D. Harispersad, at (011) 355-0814 and R. Harman, 355-0593	Gauteng Department of Education	GT/GDE/160/2007	2007-12-07	323	323
Amended details for technical information: Bushbuckridge Municipality DWAF Mpumalanga: Working for Water Programme: Clearing of Invasive Alien Plants. <i>For technical information: Contact person:</i> Linda Mabuza @ (013) 759-7492 or 082 317 2929	Bushbuckridge	W 9749	2007-12-13	944	944
Amended details for technical information: Emakhazeni Municipality DWAF Mpumalanga: Working for Water Programme: Clearing of Invasive Alien Plants. <i>For technical information: Contact person:</i> Linda Mabuza @ (013) 759-7492 or 082 317 2929	Emakhazeni	W 9750	2007-12-13	944	944
Amended details for technical information: Thaba Chweu Municipality DWAF Mpumalanga: Working for Water Programme: Clearing of Invasive Alien Plants. <i>For technical information: Contact person:</i> Linda Mabuza @ (013) 759-7492 or 082 317 2929	Thaba Chweu	W 9751	2007-12-13	944	944
Amended details for technical information: Albert Luthuli Municipality DWAF Mpumalanga: Working for Water Programme: Clearing of Invasive Alien Plants. <i>For technical information: Contact person:</i> Linda Mabuza @ (013) 759-7492 or 082 317 2929	Albert Luthuli	W 9753	2007-12-13	944	944
Amended details for technical information: Mbombela Municipality DWAF Mpumalanga: Working for Water Programme: Clearing of Invasive Alien Plants. <i>For technical information: Contact person:</i> Linda Mabuza @ (013) 759-7492 or 082 317 2929	Mbombela	W 9755	2007-12-13	944	944
Amended details for technical information: Nkomati Municipality DWAF Mpumalanga: Working for Water Programme: Clearing of Invasive Alien Plants. <i>For technical information: Contact person:</i> Linda Mabuza @ (013) 759-7492 or 082 317 2929	Nkomati	W 9756	2007-12-13	944	944
Appointment of a consultant to develop a Communication Strategy for the South African Weather Service. The top three (3) service providers with the highest points for functionality will be required to make a power-point presentation to the SAWS Evaluation Committee on 15 January 2008. Bid documents are available 24 hours per day/seven days a week from: The receptionist/security, at the main entrance, Head Office of SAWS, Bolepi House, 442 Rigel Avenue South, Erasmus Rand, Pretoria. <i>Estimated value of bid:</i> Over R500 000. Bid will be evaluated according to the 90/10 Preference Point System	South African Weather Service (401)	SAWS-0124	2007-12-14	401	401
Correction notice of tender number: Invitation for consideration as a mentor in the contractor incubator programme (CIP) . . . Category B This tender will be evaluated commensurate with the applicable scoring model at the time of evaluation.	Department of Public Works	HP07/13	2007-12-06	2	2

DESCRIPTION	REQUIRED AT	TENDER No.	DUE AT 11:00	TENDERS OBTAINABLE FROM	POST OR DELIVER TENDERS TO											
				See Annexure 1, Page 53												
<p>The following criteria is applicable:</p> <p>Preference:</p> <p>1. Historically Disadvantaged Individuals (HDI)</p> <table border="0"> <tr> <td>(a) Persons who had no franchise in national elections before the 1983 and 1993 Constitutions</td> <td>5 points</td> </tr> <tr> <td>(b) Who is a female</td> <td>3 points</td> </tr> <tr> <td>(c) Persons with disability</td> <td>2 points</td> </tr> <tr> <td>Total</td> <td>10 points</td> </tr> </table> <p>Price and quality weighting:</p> <table border="0"> <tr> <td>Quality: 60%</td> <td>Price: 40%</td> </tr> <tr> <td colspan="2">Total must equal 100%</td> </tr> </table> <p>No briefing session. Note: Documents will be sold at a non-refundable deposit of R100 CASH per set. <i>Contact for tender information:</i> Ms E P Odendaal, Tel. No. (012) 337-2179. <i>General enquiries:</i> Sipho Kubheka/Ruan Kyzer, (012) 337-2259/3038/Cell 082 852 4283</p>	(a) Persons who had no franchise in national elections before the 1983 and 1993 Constitutions	5 points	(b) Who is a female	3 points	(c) Persons with disability	2 points	Total	10 points	Quality: 60%	Price: 40%	Total must equal 100%					
(a) Persons who had no franchise in national elections before the 1983 and 1993 Constitutions	5 points															
(b) Who is a female	3 points															
(c) Persons with disability	2 points															
Total	10 points															
Quality: 60%	Price: 40%															
Total must equal 100%																

SERVICES: TRANSPORT

<p>Transportation of ± 26 km of Library Books, Machinery, Admin Files and Furniture. Site meeting on 7/12/2007, 09:00, at 239 Vermeulen Street, Committee Room. Tender document on sale at R650,00 "Cash Only"—non-refundable</p>	National Library of South Africa	NLSA-Books/01/2008	2007-12-20	540	540
---	----------------------------------	--------------------	------------	------------	------------

SPECIAL ADVERTISEMENTS

DEPARTMENT OF HEALTH**CHARLES JOHNSON MEMORIAL HOSPITAL****QUOTATIONS ARE INVITED FOR THE UNDERMENTIONED REQUIREMENTS
OF THE PROVINCIAL ADMINISTRATION OF KWAZULU-NATAL**

- (i) Quotations must be on the official quotation form, which shall be completed in all respects, and all information must be supplied as stipulated in the quotation documents.
- (ii) Quotations must be submitted in sealed envelopes.
- (iii) The envelope must be addressed to Charles Johnson Memorial Hospital, Quotation Evaluation Committee, together with the quotation number and closing date.
- (iv) The name and address of the quoting contract must be endorsed on the back of the envelope.
- (v) All Department of Health contracts awarded are subject to appeals being timeously lodged (if any) and a letter of acceptance being issued.
- (vi) Quotation documents are available from Charles Johnson Memorial Hospital, Stores Department, 92 Hlubi Street, Nqutu. Tel: (034) 271-6446.
- (vii) For quotations exceeding R30 000 an original ZNT 30 (application for preference points) form must be submitted to Charles Johnson Memorial Hospital, an original Tax Clearance Certificate must also be submitted regardless of price.

SUPPLY:	200 x 5 lt floor shine SABS approved, high gloss poly resin floor polish.
Quotation number:	ZNQ 0730-2007/2008.
Closing date:	2007-11-29.
Closing time:	11:00.
Contact person:	Mbali Mazibuko, Tel. (034) 271-6446.
SUPPLY:	200 x 5 lt floor clean non toxic non corrosive 100%, general purpose cleaner and floor stripper.
Quotation number:	ZNQ 0731-2007/2008.
Closing date:	2007-11-29.
Closing time:	11:00.
Contact person:	Mbali Mazibuko, Tel. (034) 271-6446.
SUPPLY:	200 x 5 lt floor blue general purpose mild soap detergent.
Quotation number:	ZNQ 0732-2007/2008.
Closing date:	2007-11-29.
Closing time:	11:00.
Contact person:	Mbali Mazibuko, Tel. (034) 271-6446.
SUPPLY:	300 tons small peas coal groundnut 25 x 20 mm, oxygen fast burning.
Quotation number:	ZNQ 0733-2007/2008.
Closing date:	2007-11-29.
Closing time:	11:00.
Contact person:	Mbali Mazibuko, Tel. (034) 271-6446.

OFFICE OF THE PREMIER**BIDS ARE INVITED FOR THE UNDERMENTIONED REQUIREMENTS OF THE OFFICE OF THE PREMIER FOR THE
PROVINCIAL ADMINISTRATION OF KWAZULU-NATAL**

- (i) Bids must be on the official bidding form which shall be completed in all respect and all information must be supplied as stipulated in the quotation document.
- (ii) Bids must be submitted in separate sealed envelopes.
- (iii) Separate envelopes must be used for each bid invitation.
- (iv) The address, bid number and closing date must be endorsed on the back of the envelope.
- (v) The name and address of bidders must be endorsed on the back of the envelope.
- (vi) Faxed, telegraphic, telephonic or e-mailed bids are not acceptable.
- (vii) The Office of the Premier reserves the right to reject all responses or amend, modify, postpone, withdraw or terminate the bid at any time.

- (viii) Bid documents are available from the Supply Chain Management Unit, Lower Ground Floor, Room 63, 300 Langalibalele Street, Pietermaritzburg. Tel: (033) 341-3528. **Please note:** The tender box is situated in the foyer of the Office of the Premier, Ground Floor, 300 Langalibalele Street, Pietermaritzburg.
- (ix) An original ZNT 30 document must be completed when submitting bids above R30 000 (thirty thousand rand) together with an original tax clearance certificate.
- (x) All contracts awarded are subject to appeals being timeously lodged (if any) and letters of acceptance being issued.

SERVICE:	Video Production: Office of the Premier's Service Excellence Awards.
Bid number:	KZNB 9 P/2007.
Closing time:	11:00.
Closing date:	2007-12-10.
Contact person:	Mrs S Maduray, Tel. (033) 341-3389.
Enquiries regarding specification:	Ms S Zondi, Tel. (033) 341-3441.
SERVICE:	Cleaning Service: Office of the Premier's Building (Old Telkom Building).
Bid number:	KZNB 10 P/2007.
Closing time:	11:00.
Closing date:	2007-12-21.
Contact person:	Mrs S Maduray, Tel. (033) 341-3389.
Enquiries regarding specification:	Mr D Padayachee, Cell: 082 887 3705.
<i>Compulsory site inspection:</i>	
Time:	10:00.
Date:	2007-12-14.
Venue:	Prospective bidders must meet in the foyer of the Ground Floor of the Office of the Premier's Building (Old Telkom Building).

DEPARTMENT OF HEALTH

REGIONAL LAUNDRY DURBAN AND COASTAL

BIDS ARE INVITED FOR THE UNDERMENTIONED REQUIREMENTS OF THE PROVINCIAL ADMINISTRATION OF KWAZULU-NATAL

- (i) Submissions must be on the official bid form, which shall be completed in all respects, and all information must be supplied.
- (ii) Bids must be submitted in sealed envelopes.
- (iii) The envelope must be addressed to Regional Laundry Durban and Coastal together with the bid number and closing date.
- (iv) The name and address of the bidder must be endorsed on the back of the envelope.
- (v) All Department of Health Contracts awarded are subject to appeals being timeously lodged (if any).
- (vi) Bid documents are available from Regional Laundry Durban & Coastal, 9 Sea Cow Lake, Durban, 4001.

INVITATION OF BIDS

SERVICE:	Supply and fit one coal screw for boiler no. 1.
Bid number:	ZNQ 252/2007.
Closing date:	2007-12-07.
Closing time:	11:00.
Compulsory site inspection:	
Date:	2007-11-28.
Time:	11:00.
Contact person:	Mrs Tamara, Daniels, Tel. (031) 579-4660.
Enquiries regarding the specification:	Mr Daya, Pillay, Tel. (031) 579-4660.
SERVICE:	Pest Control (1 year contract).
Bid number:	ZNQ 222/2007.
Closing date:	2007-12-07.
Closing time:	11:00.
Compulsory site inspection:	
Date:	2007-11-29.
Time:	11:00.
Contact person:	Mrs Tamara, Daniels, Tel. (031) 579-4660 Ext. 311.
SERVICE:	Service Boiler No. 1.
Bid number:	ZNQ 239/2007.
Closing date:	2007-12-07.
Closing time:	11:00.

Compulsory site inspection:
 Date: 2007-11-29.
 Time: 11:00.
 Contact person: Mrs Tamara, Daniels, Tel. (031) 579-4660.
 Enquiries regarding the specification: Mr Daya, Pillay, Tel. (031) 579-4660.

DEPARTMENT OF HEALTH

CLAIRWOOD HOSPITAL

QUOTATIONS ARE INVITED FOR THE UNDERMENTIONED REQUIREMENTS FOR THE PROVINCE OF KWAZULU-NATAL

- (1) Quotations must be on the official quotation form, which shall be completed in all respects, and all information must be supplied as stipulated in the quotation document.
- (2) Quotations must be submitted in sealed envelopes.
- (3) Separate envelopes must be used for each quotation.
- (4) The envelopes must be addressed to the Department of Health, Clairwood Hospital, together with the quotation number and closing date.
- (5) The name and address of the quoting contractor must be endorsed on the back of the envelope.
- (6) All Department of Health contracts awarded are subject to appeals being lodged (if any) and letters of acceptance being issued.
- (7) Quotation documents are available from the Department of Health, Clairwood Hospital, Mobeni. Tel: (031) 451-5071. Fax: (031) 462-0430.

SUPPLY: Eggs medium for the period 2008-01-01 to 2008-06-30.

Quotation number: ZNQ 575-2007h.
 Closing date: 2007-12-04.
 Closing time: 11:00.
 Contact person: Kessie Govindsamy, Tel. (031) 451-5071.
 Enquiries regarding specifications: Kay Naidoo, Tel. (031) 451-5126.

SUPPLY: Milk, maas, juice and mmandi for the period 2008-01-01 to 2008-06-30.

Quotation number: ZNQ 574-2007h.
 Closing date: 2007-12-04.
 Closing time: 11:00.
 Contact person: Kessie Govindsamy, Tel. (031) 451-5071.
 Enquiries regarding specifications: Kay Naidoo, Tel. (031) 451-5126.

SUPPLY: Chicken portions, livers, barrered fish, deboned hake fillets and frozen vegetables for the period 2008-01-01 to 2008-06-30.

Quotation number: ZNQ 576-2007h.
 Closing date: 2007-12-04.
 Closing time: 11:00.
 Contact person: Kessie Govindsamy, Tel. (031) 451-5071.
 Enquiries regarding specifications: Kay Naidoo, Tel. (031) 451-5126.

SUPPLY: Fresh fruit and vegetables for the period 2008-01-20 to 2008-06-30.

Quotation number: ZNQ 573-2007h.
 Closing date: 2007-12-04.
 Closing time: 11:00.
 Contact person: Kessie Govindsamy, Tel. (031) 451-5071.
 Enquiries regarding specifications: Kay Naidoo, Tel. (031) 451-5126.

SUPPLY: Beef quarters for the period of 2008-01-10 to 2008-06-30.

Quotation number: ZNQ 577-2007h.
 Closing date: 2007-12-04.
 Closing time: 11:00.
 Contact person: Kessie Govindsamy, Tel. (031) 451-5071.
 Enquiries regarding specifications: Kay Naidoo, Tel. (031) 451-5126.

SUPPLY: White and brown bread for the period 2008-01-01 to 2008-06-30.

Quotation number: ZNQ 578-2007H.
 Closing date: 2007-12-04.
 Closing time: 11:00.
 Contact person: Kessie Govindsamy, Tel. (031) 451-5071.
 Enquiries regarding specifications: Kay Naidoo, Tel. (031) 451-5126.

SUPPLY:	Mutton, steak, mince and beef sausage for the period 2008-01-01 to 2008-06-30.
Quotation number:	ZNQ 582-2007h.
Closing date:	2007-12-04.
Closing time:	11:00.
Contact person:	Kessie Govindsamy, Tel. (031) 451-5071.
Enquiries regarding specifications:	Kay Naidoo, Tel. (031) 451-5126.
SERVICE:	Pauper burial for the period 2008-01-01 to 2008-06-30.
Quotation number:	ZNQ 581-2007h.
Closing date:	2007-12-04.
Closing time:	11:00.
Contact person:	Kessie Govindsamy, Tel. (031) 451-5071.
Enquiries regarding specifications:	Kay Naidoo, Tel. (031) 451-5126.

DEPARTMENT OF HEALTH

THULASIZWE HOSPITAL

QUOTATIONS ARE INVITED FOR THE UNDERMENTIONED REQUIREMENTS OF THE PROVINCIAL ADMINISTRATION OF KWAZULU-NATAL

- (i) Quotations must be on the official quotation form, which shall be completed in all respect, and all information must be supplied as stipulated in the quotation document.
- (ii) Quotations must be submitted in sealed envelopes.
- (iii) Separate envelopes must be used for each quotation.
- (iv) The envelope must be addressed to Thulasizwe Hospital Quotations, Evaluation Committee together with the quotation number and closing date.
- (v) The name and address of the quoting contractor must be endorsed on the back of the envelope.
- (vi) All Department of Health contracts awarded, are subject to appeals being lodged (if any) and letters of acceptance being issued.
- (vii) Please complete original ZNT 30 Documents when submitting quotations above R30 000 (thirty thousand rand) together with the original tax clearance certificate.
- (viii) Whether a tender complies with SABS/SANS/CKS/legislated and any Standards must be specified in the tender document.
- (ix) Tender must comply with the specification.
- (ix) Quotations documents are available from Thulasizwe Hospital, Stores Department, Private Bag X206, Ceza, 3866. Tel. (035) 832-0003/0197. Fax (035) 823-0061/62.

SUPPLY:	Supply and installation of wall oxygen and wall suction.
Quotation number:	ZNQ188/2007-2008.
Closing date:	03/12/2007.
Closing time:	11h00.
Contact person:	Mandla Qwabe, (035) 832-0003/0197.
Contact fax no.:	(035) 832-0061/62.

DEPARTMENT OF HEALTH

GREYS PROVINCIAL HOSPITAL

QUOTATIONS ARE INVITED FOR THE UNDERMENTIONED REQUIREMENTS OF THE PROVINCIAL ADMINISTRATION OF KWAZULU-NATAL

- (i) Quotations must be on the official quotation form, which shall be completed in all respects, and all information must be supplied as stipulated in the quotation document.
- (ii) Quotations must be submitted in sealed envelopes.
- (iii) Separate envelopes must be used for each quotation.
- (iv) The envelope must be addressed to Grey's Provincial Hospital, Quotation Evaluation Committee together with the quotation number and closing date.
- (v) The name and addresse of the quoting contractor must be endorsed on the back of the envelope.
- (vi) All Department of Health contracts awarded, are subject to appeals being timeously lodged (if any) and letters of acceptance being issued.

- (vii) Quotation documents are available from Grey's Provincial Hospital, Supplies Division, Town Bush Road, and Pietermaritzburg. Tel. (033) 897-3478, Fax (033) 342-4288.
- (viii) For quotations exceeding R30 000,00 and original ZNT 30 (application for preference points) form must be submitted to Grey's Provincial Hospital, an original tax clearance certificate must also be submitted regardless of price.

SUPPLY: 2 of elctrosurgical unit—High Power. As per specifications.
 H.T.U. Specification: H.T.S. No. 5/1997 (Electronics).
 UMNDS Number: 11490.
 Quotation number: ZNQ 90/11/07.
 Closing date: 11 December 2007.
 Closing time: 11.00 am.
 Contact person: Mr S.A. Ndlovu, (033) 897-3478.
 Enquiries regarding specification: MR S.A. Ndlovu, (033) 897-3478.

DEPARTMENT OF HEALTH

BIDS ARE INVITED FOR THE UNDERMENTIONED REQUIREMENTS OF THE PROVINCIAL ADMINISTRATION OF KWAZULU-NATAL

MAHATMA GANDHI MEMORIAL HOSPITAL

- (i) Bids must be on the official tender form, which shall be completed in all respects and all information must be supplied as stipulated in the bid documents.
- (ii) Each bid must be in a sealed envelope.
- (iii) The envelope must be addressed to Mahatma Gandhi Memorial Hospital, Bid Evaluation Committee together with the bid number and closing date.
- (iv) The name and address of the quoting contractor must be endorsed on the back of the envelope.
- (v) All contractors must duly complete and sign new ZNT 30 documents for Preferential Point Calculation.
- (vi) No faxed copies of Bid documents will be accepted.
- (vii) All Department of Health contractors awarded are subject to appeal being timeously lodged (if any) and letter of acceptance being issued.
- (viii) Bid documents are available from the Department of Health (Mahatma Gandhi Memorial Hospital).
Tel: (031) 502-1719. Fax: (031) 502-1867.

SERVICE: Management of HIV/AIDS in the workplace (in-service) as per specification.
 Bid number: ZNQ 1827/07.
 Closing date: 2007-12-07.
 Closing time: 11:00.
 Enquiries regarding specification: Mrs T.D. Khwela, Tel. (031) 502-1719, Ext. 2095.
 Contact person: Mr M. Pillay, Tel: (031) 502-1719 Ext. 2225.

SERVICE: To compile and update the training manual for Labour Relations and conduct training for 30 HR officers as per specification.
 Bid number: ZNQ 1828/07.
 Closing date: 2007-12-07.
 Closing time: 11:00.
 Enquiries regarding specification: Mrs T.D. Khwela, Tel. (031) 502-1719, Ext. 2095.
 Contact person: Mr M. Pillay, Tel: (031) 502-1719 Ext. 2225.

SERVICE: To conduct customer care course for 40 people as per specification.
 Bid number: ZNQ 1829/07.
 Closing date: 2007-12-07.
 Closing time: 11:00.
 Enquiries regarding specification: Mrs T.D. Khwela, Tel. (031) 502-1719, Ext. 2095.
 Contact person: Mr M. Pillay, Tel: (031) 502-1719 Ext. 2225.

THE INSURANCE SECTOR EDUCATION AND TRAINING AUTHORITY (INSETA)

REQUEST FOR BIDS:

TENDER IPO/13/2007—DEVELOPMENT OF A BETTER BUSINESS TOOLKIT FOR SMME BROKERAGES

The Insurance Sector Education and Training Authority (INSETA) invites suitably qualified providers to submit a proposal for consideration, to be appointed subject to the provisions of this RFB that can—

- research and develop a business development and business management “toolkit”, and
- that can provide training on the toolkit and the use thereof.

Contact for inquiries:

Inquiries related to this RFB may only be addressed for the attention of Ms Shamika Pillay at the following address:

E-mail address: insetapo@exordia.co.za reference "Tender IPO/13/2007".

Only written enquiries, submitted to the above e-mail or faxed to (011) 209-5448, will be accepted until Monday, 7 January 2008.

Procurement schedule:

Potential Service Providers ("Service Provider" to this RFB) are to adhere to the following schedule of events in this procurement process. The INSETA reserves the right to change this schedule at any time. Parties concerned will be notified as and when necessary:

Publishing of RFB	Newspapers—18 November 2007. Tender bulletin—23 November 2007.
Deadline for response to the RFB	11 January 2008 @ 11:00
Selection/short listing	15 January 2008
Proposals presentations at final evaluation	18 January 2008
Appointment of selected Service Providers	25 January 2008

The Request for Bid (RFB) can be accessed from INSETA's website at www.inseta.org.za

Interested parties can collect the RFB documents from the following address: INSETA Programme Office, PriceWaterhouseCoopers, East Wing, 2 Eglin Road, Sunninghill.

INSETA Programme Office hours are 08:30–16:00. Please call extension 5448 at reception.

All proposals must be submitted to the INSETA Programme Office by 11:00 on Friday, 11 January 2008.

Proposals must be sent to Ms Shamika Pillay, INSETA Programme Office, East Wing E/2/44B, 2 Eglin Road, PriceWaterhouseCoopers, Sunninghill, 2157.

Please note that electronic or late entries will not be accepted!

LEPELLE NORTHERN WATER (LNW)

BID No. LNW 65/07 STAFF HOUSES:

FOR OLIFANTSPOORT: THE CONSTRUCTION OF THE EXTENSION OF THE EXISTING WATER PURIFICATION WORKS TO 60 MI/DAY: PHASE 2—STAFF HOUSES

BID NOTICE

Bidders are hereby invited to bid for the construction of the extension of the existing water purification works at Olifantspoort to 60 MI/day (Phase 2). Bidders must be registered with the CIDB of class 4SP or higher class.

Bid documents will be available as from Monday, 19 November 2007, upon payment of a non-refundable cash document fee of R300,00 per set, from the offices of Lepelle Northern Water, No. 22 Hans van Rensburg Street, Bonita's Building, Block B, Polokwane. Telephone No. (015) 295-1800. Bid documents are obtainable during the following office hours: 08h00 to 16h00 (Monday to Friday).

A compulsory site inspection will be held at 10h00, on Friday, 23 November 2007. Prospective bidders are requested to meet on the said date and time at LNW pump station No. 2, opposite the Lebowakgomo show grounds, from where they will be accompanied to the site. Contract documentation will not be available at the site inspection.

Bids are to be completed in accordance with the conditions and bid rules contained in the Bid Documents and all documents must be sealed and externally endorsed with the CONTRACT NUMBER and DESCRIPTION and placed in the tender box, at the offices of LNW in Polokwane, not later than 11h00 on Friday, 11th January 2008. Bids will be opened in Public immediately thereafter. All bids shall hold good for 90 days as from the closing date of bids. **Please note that all 4 volumes of the contract must be returned with the offer.**

Bid documents which are not received and/or deposited in the tender box before 11:00 on the closing date for the Bid mentioned hereinbefore, will be marked as late Bids and such Bid documents shall in terms of the Procurement Policy of LNW, not be considered by the Board.

Enquiries must be directed to the Project Manager of Consulting Engineers Ingerop South Africa, for attention: Mr A. Botha, at Tel. No. (011) 808-3008 or Mr K. Nkwada, at Tel. No. (015) 295-5810.

Bidder's attention is specifically drawn to the provisions of the bid rules, which are included in the Bid documents. The lowest or any bid will not necessarily be accepted and LNW reserves the right not to consider any tender not suitably endorsed or comprehensively completed, as well as the right to accept a tender in whole or part.

It is anticipated that this is categorised as a bid where the 90/10 preferential points system will be used in terms of the Preferential Procurement Policy Framework Act, to evaluate bids.

Mr N P A Bopape, Chief Financial Officer

LEPELLE NORTHERN WATER (LNW)

BID No. LNW 67/07 CIVIL

FOR OLIFANTSPOORT: THE CONSTRUCTION OF THE EXTENSION OF THE EXISTING WATER PURIFICATION WORKS TO 60 MI/DAY: PHASE 2—CIVIL WORKS

BID NOTICE

Bidders are hereby invited to bid for the construction of the extension of the existing water purification works at Olifantspoort to 60 MI/day (Phase 2). Bidders must be registered with the CIDB of class 8 CE or higher class. Phase 2 works will be implemented with four main contracts (Staff housing, Electro-mechanical works, main civil works and building works) and includes supply, delivery to site, installation, commissioning and maintenance for a 12-month period of earth works, a new raw water rising main, sedimentation tank units, rapid gravity filter units, a new contact tank, a new air blower building, a new electrical substation building, plant for on site chlorine production, emptying of two existing sludge lagoons and construction of two new sludge lagoons, chemical dosing equipment, extensions to associated pipework, valves and other ancillary equipment for the treatment of potable water standards at the existing Olifantspoort water purification works as well as the existing booster pump stations 2 and 3 of the Olifants-Sand Water Transfer pumping main, delivering water to Polokwane.

Bid No LNW 67/07 Civil consists of the construction of the main Civil Works as described in detail in the documentation and includes a new raw water rising main, sedimentation tank units, rapid gravity filter units, a new contact tank, a new air blower building, a new electrical substation building, chemical dosing equipment, extensions to associated pipework, valves and other ancillary equipment.

This work must be completed in stages as stipulated in detail in the Bid document.

Bid documents will be available as from Monday, 19 November 2007, upon payment of a non-refundable cash document fee of R1 500,00 per set, from the offices of Lepelle Northern Water, No. 22 Hans van Rensburg Street, Bonita's Building, Block B, Polokwane. Telephone No. (015) 295-1800. Bid documents are obtainable during the following office hours: 08h00 to 16h00 (Monday to Friday).

A compulsory site inspection will be held at 10h00, on Monday, 26 November 2007. Prospective bidders are requested to meet on the said date and time at LNW pump station No. 2, opposite the Lebowakgomo show grounds, from where they will be accompanied to the site. Contract documentation will not be available at the site inspection.

Bid documents are to be completed in accordance with the conditions and bid rules contained in the Bid Documents and all documents must be sealed and externally endorsed with the CONTRACT NUMBER and DESCRIPTION and placed in the tender box, at the offices of LNW in Polokwane, not later than 11h00 on Friday, 1st February 2008. Bids will be opened in Public immediately thereafter. All bidders shall hold good for 90 days as from the closing date of bids. **Please note that all 8 volumes of the contract must be returned with the offer.**

Bid documents that are not received and/or deposited **in the tender box before 11:00** on the closing date for the tender mentioned hereinbefore, will be marked as late bid documents and such documents shall in terms of the Procurement Policy of LNW, not be considered by the Board.

Bidder's attention is specifically drawn to the provisions of the bid rules, which are included in the Bid document. The lowest or any bid will not necessarily be accepted and LNW reserves the right not to consider any tender not suitably endorsed or comprehensively completed, as well as the right to accept a tender in whole or part. It is anticipated that this is categorised as a tender where the 90/10 preferential points system will be used in terms of the Preferential Procurement Policy Framework Act, to evaluate bids.

Enquiries must be directed to the Project Manager of Consulting Engineers Ingerop South Africa, for attention: Mr A. Botha, at Tel. No. (011) 808-3008 or Mr K. Nkwada, at Tel. No. (015) 295-5810.

Mr N P A Bopape, Chief Financial Officer

RAF (ROAD ACCIDENT FUND)

INVITATION TO MEDICAL AND OTHER EXPERTS TO BE ON THE RAF SUPPLIER DATABASE (REF. RAF/HO/00038)

The Road Accident Fund (RAF) is a statutory body that, in terms of the provisions of the Road Accident Fund Act, 1996 (Act 56 of 1996), exists to provide compensation to persons who have suffered loss or damage wrongfully caused by motor vehicle accidents.

The Road Accident Fund receives approximately 170 000 claims per year and finalises approximately 260 000 claims per year.

The compensation paid by the RAF, as determined by the RAF Act and the common law of delict, includes the following:

1. Past and future medical related expenses.
2. Past and future earnings.
3. Past and future loss of support.
4. Funeral expenses.

In assessing the extent of injuries, functional impairment and quantum of loss arising from a claim lodged with the RAF in terms of the RAF Act, the RAF requires the service of medical and other experts to:

- Provide medical expert reports on the injury sustained in the motor vehicle accident.
- Determine if the injury will affect the earning capacity and/or impact of the injury on daily living.
- Determine future medical treatment required based on the injury sustained in the motor vehicle accident.
- Provide medical expert advisory service.
- Provide medico legal reports.
- Determine impact of the injury on the earning capacity.
- Determine impact of the injury on loss of support claims.
- Determine the career path of the claimant before the accident and after the accident.
- Determine the quantum of future and past loss of income.

The Road Accident Fund request medical and other experts to apply to be on a RAF supplier database. Experts in the following field but not limited to:

- Specialist physicians.
- Disability medicine.
- Evaluation of impairment.
- Occupational and family medicine.
- All surgeons.
- Maxillo facial and oral surgeon.
- Neurosurgeon.
- Neurologists.
- Ear, nose and throat specialist.
- Orthopaedic surgeon.
- Industrial psychologists.
- Child psychologist.
- Clinical psychologist.
- Cardiac specialists.
- Sepsis specialist.
- Ophthalmic surgeon.
- Medical General practitioners.
- Forensic accounting services.
- Accountants.
- Actuaries.

Documents specifying details of the above services required by the RAF will be available via e-mail from charmainew@raf.co.za or www.raf.co.za

Documents must be sealed in an envelope and clearly marked with the name and RAF reference number. Please submit your proposal to: The Procurement Manager, Road Accident Fund, 38 Ida Street, Menlo Park, Pretoria **or** charmainew@raf.co.za

Closing date: 11 December 2007.

Closing time: 14h00.

Enquiries: charmainew@raf.co.za

The RAF is committed to affirmative procurement consistent with the South African Constitution, the Preferential Procurement Policy Framework Act of 2000 and the Procurement Policy of the RAF. Preference will be given to individuals and such companies, owned or controlled by individuals from previously disadvantaged categories of South Africa.

Submission of the forms does not automatically put a service provider in the Database of the RAF experts.

RAF is under no obligation to accept any proposal.

DEPARTMENT OF HEALTH

BENEDICTINE PROVINCIAL HOSPITAL

QUOTATIONS ARE INVITED FOR THE UNDERMENTIONED REQUIREMENTS OF THE PROVINCIAL ADMINISTRATION OF KWAZULU-NATAL

- (i) Quotations must be on the official quotation form, which shall be completed in all respects, and all information must be supplied as stipulated in the quotation document.
- (ii) Quotations must be submitted in sealed envelopes/fax.
- (iii) Separate envelopes must be used for each quotation.

- (iv) The envelopes must be addressed to the Department of Health: Benedictine Provincial Hospital, quotations Evaluation committee together with the quotation number and closing date.
- (v) The name and address for the quoting contractor must be endorsed on the back of the envelope.
- (vi) All Department of Health contracts awarded are subjects to appeals being timeously lodged (if any) and letters of acceptance being issued.
- (vii) Please complete original ZNT 30 documents when submitting quotations above R30 000 (thirty thousand rand) together with an original Tax Clearance Certificate.
- (viii) Quotation documents are available from Benedictine Provincial Hospital Stores Department, Tel. (035) 831-7157, Fax (035) 831-3241.
- (ix) To obtain quotation forms, please fax your request to the number stipulated above. No calls will be taken, except for queries relating to specification that are not clearly understood, see number of contact person.

Invitation of quotation

SUPPLY:	100 x bed call system-small bells for all wards.
Quotation number:	ZNQ 47/2007-2008.
Closing date:	2007-11-30.
Closing time:	11:00.
Contact person:	Mr N.L.N. Nzuza, Tel. (035) 831-7077.
Enquiries regarding specification:	Mr N.L.N. Nzuza, Tel. (035) 831-7077.
SUPPLY:	100 x VacuSmart suction liners 700 mls for anaesthetics machines.
Quotation number:	ZNQ 48/2007-2008.
Closing date:	2007-11-30.
Closing time:	11:00.
Contact person:	Mr N.L.N. Nzuza, Tel. (035) 831-7077.
Enquiries regarding specification:	Mr N.L.N. Nzuza, Tel. (035) 831-7077.
SUPPLY:	1 x NIBP monitor.
Quotation number:	ZNQ 49/2007-2008.
Closing date:	2007-11-30.
Closing time:	11:00.
Contact person:	Mr N.L.N. Nzuza, Tel. (035) 831-7077.
Enquiries regarding specification:	Mr N.L.N. Nzuza, Tel. (035) 831-7077.
SUPPLY:	2 x 2 extra ports for vacuum.
Quotation number:	ZNQ 50/2007-2008.
Closing date:	2007-11-30.
Closing time:	11:00.
Contact person:	Mr N.L.N. Nzuza, Tel. (035) 831-7077.
Enquiries regarding specification:	Mr N.L.N. Nzuza, Tel. (035) 831-7077.

DEPARTMENT OF HEALTH

BENEDICTINE PROVINCIAL HOSPITAL

QUOTATIONS ARE INVITED FOR THE UNDERMENTIONED REQUIREMENTS OF THE PROVINCIAL ADMINISTRATION OF KWAZULU-NATAL

- (i) Quotations must be on the official quotation form, which shall be completed in all respects, and all information must be supplied as stipulated in the quotation document.
- (ii) Quotations must be submitted in sealed envelopes/fax.
- (iii) Separate envelopes must be used for each quotation.
- (iv) The envelopes must be addressed to the Department of Health: Benedictine Provincial Hospital, quotations Evaluation committee together with the quotation number and closing date.
- (v) The name and address for the quoting contractor must be endorsed on the back of the envelope.
- (vi) All Department of Health contracts awarded are subjects to appeals being timeously lodged (if any) and letters of acceptance being issued.
- (vii) Please complete original ZNT 30 documents when submitting quotations above R30 000 (thirty thousand rand) together with an original Tax Clearance Certificate.
- (viii) Quotation documents are available from Benedictine Provincial Hospital Stores Department, Tel. (035) 831-7157, Fax (035) 831-3241.

- (ix) To obtain quotation forms, please fax your request to the number stipulated above. No calls will be taken, except for queries relating to specification that are not clearly understood, see number of contact person.

Invitation of quotation

SUPPLY:	19 x adult cot beds.
Quotation number:	ZNQ 56/2007-2008.
Closing date:	2007-11-30.
Closing time:	11:00.
Contact person:	Mr N.L.N. Nzuzi, Tel. (035) 831-7077.
Enquiries regarding specification:	Mr N.L.N. Nzuzi, Tel. (035) 831-7077.
SUPPLY:	22 x mattresses with durable plastic covers.
Quotation number:	ZNQ 57/2007-2008.
Closing date:	2007-11-30.
Closing time:	11:00.
Contact person:	Mr N.L.N. Nzuzi, Tel. (035) 831-7077.
Enquiries regarding specification:	Mr N.L.N. Nzuzi, Tel. (035) 831-7077.
SUPPLY:	5 x pastor chairs (bundles of 5) colour maroon or advocado for 20 people.
Quotation number:	ZNQ 58/2007-2008.
Closing date:	2007-11-30.
Closing time:	11:00.
Contact person:	Mr N.L.N. Nzuzi, Tel. (035) 831-7077.
Enquiries regarding specification:	Mr N.L.N. Nzuzi, Tel. (035) 831-7077.
SUPPLY:	1 x delivery bed with stirrups.
Quotation number:	ZNQ 59/2007-2008.
Closing date:	2007-11-30.
Closing time:	11:00.
Contact person:	Mr N.L.N. Nzuzi, Tel. (035) 831-7077.
Enquiries regarding specification:	Mr N.L.N. Nzuzi, Tel. (035) 831-7077.
SUPPLY:	6 x Pastor chairs (bundles of 5) maroon or advocado.
Quotation number:	ZNQ 59/2007-2008.
Closing date:	2007-11-30.
Closing time:	11:00.
Contact person:	Mr N.L.N. Nzuzi, Tel. (035) 831-7077.
Enquiries regarding specification:	Mr N.L.N. Nzuzi, Tel. (035) 831-7077.
SUPPLY:	16 x U.V. Germicidal irradiation system to control the spread of PTB.
Quotation number:	ZNQ 60/2007-2008.
Closing date:	2007-11-30.
Closing time:	11:00.
Contact person:	Mr N.L.N. Nzuzi, Tel. (035) 831-7077.
Enquiries regarding specification:	Mr N.L.N. Nzuzi, Tel. (035) 831-7077.

DEPARTMENT OF HEALTH

LOWER UMFOLOZI DISTRICT WAR MEMORIAL HOSPITAL

QUOTATIONS ARE INVITED FOR THE UNDERMENTIONED REQUIREMENTS OF THE PROVINCIAL ADMINISTRATION OF KWAZULU-NATAL

- (i) Quotation must be on the official quotation form, which shall be completed in all respects.
- (ii) Each quotation must be submitted in a sealed envelope.
- (iii) The envelope must be addressed to Lower Umfolozi District War Memorial Hospital, Quotation Evaluation Committee, together with the quotation number and closing date.
- (iv) The name and address of the quoting contractor must be endorsed on the back of the envelope.
- (v) All Department of Health contracts awarded are subject to appeals being timeously lodged (if any) and a letter of acceptance being issued.
- (vi) Quotation documents are available from Lower Umfolozi District War Memorial Hospital, Security Division, Union Street, Empangeni. Tel: (035) 902-8503. Fax: (035) 772-6630.
- (vii) To obtain quotation forms, please fax your request to the number below. No calls will be taken, except for queries relating to specifications that are not clearly understood. See number of contact person.

Bids cancelled:

SUPPLY:	Syringe sterile 10 ml 3 port.
Quotation number:	ZNQ 1355/2007/08.
Closing date:	2007/10/11.
Closing time:	11:00.
Contact person:	Ms M. Mncwango, Tel: (035) 902-8503.
SUPPLY:	Syringe sterile 2 ml.
Quotation number:	ZNQ 1339/2007/08.
Closing date:	2007/10/11.
Closing time:	11:00.
Contact person:	Ms M. Mncwango, Tel: (035) 902-8503.
SUPPLY:	White long sleeve disposable jackets.
Quotation number:	ZNQ 1225/2007/08.
Closing date:	2007/10/04.
Closing time:	11:00.
Contact person:	Ms M. Mncwango, Tel: (035) 902-8503.

Re-advertising of bids:

SUPPLY:	Team building for 45 supervisors.
Quotation number:	ZNQ 1685/2007/08.
Closing date:	2007/12/06.
Closing time:	11:00.
Contact person:	Ms M. Mncwango, Tel: (035) 902-8503.
SUPPLY:	Syringes sterile 10 ml 3 part.
Quotation number:	ZNQ 1730/2007/08.
Closing date:	2007/12/06.
Closing time:	11:00.
Contact person:	Ms M. Mncwango, Tel: (035) 902-8503.
SUPPLY:	Syringes sterile 2 ml.
Quotation number:	ZNQ 1731/2007/08.
Closing date:	2007/12/06.
Closing time:	11:00.
Contact person:	Ms M. Mncwango, Tel: (035) 902-8503.
SUPPLY:	Tubes nasal feeding 6 fg 400 mm medica.
Quotation number:	ZNQ 1732/2007/08.
Closing date:	2007/12/06.
Closing time:	11:00.
Contact person:	Ms M. Mncwango, Tel: (035) 902-8503.

Awards of bids:

SERVICES:	Washed peas coal.
Quotation number:	ZNQ 852/2007/08.
Contractor:	Mlina's Trading.
SERVICES:	Project management for 20 supervisors.
Quotation number:	ZNQ 1224/2007/08.
Contractor:	Business Studies Unit/DUT.

DEPARTMENT OF HEALTH**MONTEBELLO HOSPITAL****QUOTATIONS ARE INVITED FOR THE UNDERMENTIONED REQUIREMENTS
OF THE PROVINCIAL ADMINISTRATION OF KWAZULU-NATAL**

- (i) Quotations must be on the official quotation form, which shall be completed in all respects, and all information must be supplied as stipulated in the quotation document.
- (ii) Quotations must be submitted in sealed envelopes.
- (iii) The address, quotation number and closing date must be endorsed at the front of the envelope.
- (iv) The name and address of the company must be endorsed at the back of the envelope.
- (v) All Department of Health contracts awards are subject to appeals being lodged (if any) and letters of acceptance being issued.

- (vi) Quotation documents are available from Montebello Hospital Stores, R614 Noordsberg Road, Tel: (033) 506-7033, Fax: (033) 506-0058.
- (vii) For quotations exceeding R30 000,00 an original ZNT 30 (application for preference points) and original tax clearance certificate must be submitted to the above-mentioned address.

SERVICE: Cleaning of gardens & grounds for clinics under Montebello Hospital (Chibini, Esidumbini, Kwanyuswa, Thafamasi and Wosiyane)—3 months..

Quotation number: ZNQ 318-2007/08.

Closing date: 6 December 2007.

Closing time: 11h00.

Contact person: Mrs S.J. Gumede/Mr N.C. Dladla, (033) 506-7033.

Enquiries regarding specification: Mr S'boniso Mthembu, (033) 506-7113.

DEPARTMENT OF HEALTH

UMGUNGUNDLOVU DISTRICT OFFICE—BRASFORT HOUSE QUOTATIONS ARE INVITED FOR THE UNDERMENTIONED REQUIREMENTS OF THE PROVINCIAL ADMINISTRATION OF KWAZULU-NATAL

- (i) Quotations must be on the official form, which shall be completed in all respects and all information must be supplied as stipulated in the quotation document.
- (ii) Each quotation must be submitted in a sealed envelope.
- (iii) The envelope must be addressed to District 22 Health Office, together with the quotation number and closing date.
- (iv) The name and number of the quoting contractor must be endorsed on the back of the envelope.
- (v) All Department of Health contractors awarded are subject to appeals being timeously lodged (if any) and letters of acceptance being issued.
- (vi) Quotation documents are available from the Department of Health: Brasfort House, Telephone (033) 897-1023.

SUPPLY: Alterations to Psychiatric Department at East/Boom Community Health Centre.

Quotation number: ZNQ800/07/08.

Closing date: 2007-11-30.

Closing time: 11:00.

Contact person: Miss Z. Mdingi.

SUPPLY: New fence around MDR wards at Doris Goodwin Hospital.

Quotation number: ZNQ801/07/08.

Closing date: 2007-11-30.

Closing time: 11:00.

Contact person: Miss. Z. Mdingi.

SUPPLY: New fence including sliding gates new electrical installation and CCTV system to new Stepdown facility at Umngei Hospital.

Quotation number: ZNQ802/07/08.

Closing date: 2007-11-30.

Closing time: 11:00.

Contact person: Miss. Z. Mdingi.

Enquiries regarding the specification: Miss Z. Mdingi, Tel. (033) 897-1023.

DEPARTMENT OF HEALTH

QUOTATIONS ARE INVITED FOR THE UNDERMENTIONED REQUIREMENTS OF GJ CROOKES PROVINCIAL HOSPITAL OF KWAZULU-NATAL

1. Quotations must be on the official quotation form, which shall be completed in all respects, and all information must be supplied as stipulated in the quotation document.
2. Quotations must be submitted in sealed envelopes.
3. Separate envelopes must be used for each quotation.
4. The envelope must be addressed to GJ Crookes Provincial Hospital, Quotation Evaluation Committee together with the quotation number and closing date.
5. The name and address of the quoting contractor must be endorsed on the back of the envelope.
6. All Department of Health contracts awarded are subject to appeals being timeously lodged (if any) and letters of acceptance being issued.

7. An original ZNT 30 form must be completed when submitting quotations above R30 000 (thirty thousand rand) together with an original Tax Clearance Certificate.
8. Quotation and Specification documents will be handed out at the site meeting.

SUPPLY:	Security services to perform 24hour access control and perimeter patrol at G.J. Crookes Hospital for the month of January 2008 (Guards must have a minimum of a Grade "D").
Quotation Number:	ZNQ 684 of 2007.
Closing date:	2007-12-06.
Closing time:	11:00.
Compulsory site meeting date:	2007-11-30.
Time:	10:00.
Venue:	Lecture room.
Contact person:	Ms R.E. Weldon, Tel. (039) 978-7048.
Enquiries regarding specification:	Mr M.A. Ngidi, Tel. (039) 978-7010.

DEPARTMENT OF HEALTH

MURCHISON HOSPITAL

BIDS ARE INVITED FOR THE UNDERMENTIONED REQUIREMENTS OF THE PROVINCIAL ADMINISTRATION OF KWAZULU-NATAL

- (i) Bids must be on the official bid/quotation form, which shall be completed in all respects, and all information must be supplied as stipulated in the quotation document.
- (ii) Bids must be submitted in separate (one bid per envelope) sealed envelopes and placed in the tender box situated at the security entrance.
- (iii) The envelope must be addressed to the Department of Health, Murchison Hospital, Private Bag X701, Port Shepstone, 4240, together with the bid number and closing date on the front of the envelope.
- (iv) The name and address of the bidder must be endorsed on the back of the envelope.
- (v) The bidder must be registered on the Suppliers' Database, as well as the Basic Accounting System (BAS).
- (vi) An original ZNT 30 (Application for preference points) form and valid original tax clearance certificate must be submitted with the bid.
- (vii) Bid documents are available from the Department of Health, Murchison Hospital, N2 Main Harding Road, Port Shepstone, Hibiscus Coast, 4240. Tel. (039) 687-7311 Ext. 2251. Facsimile: (039) 687-7690.

SUPPLY/SERVICE: To supply and deliver: 1 x Continuous Positive Airway Pressure System—Nasal Prong Specification H.T.S. A34A (anaesthetics) UMDNS: 13360.
1 x Compressor Medical Air (Capacity: 60 L.M.P.) Specification H.T.S. A33A (anaesthetics) UMDNS: 10972.

Bid number: ZNQ S783/2007/2008.
Closing date and time: 06/12/2007 @ 11h00.
Enquiries: Mr F.V. Nyawose/Mr F. Barth.

SUPPLY/SERVICE: To supply and deliver: 1 x Defibrillator Monitor—Portable, ECG& SPO2, Specification H.T.S. 8/1998 (electronics) UMDNS: 11129.

Bid number: ZNQ S785/2007/2008.
Closing date and time: 06/12/2007 @ 11H00.
Enquiries: Mr F.V. Nyawose/Mr F. Barth.

DEPARTMENT OF HEALTH

EDENDALE HOSPITAL

BIDS ARE INVITED FOR THE UNDERMENTIONED REQUIREMENTS OF THE PROVINCIAL ADMINISTRATION OF KWAZULU-NATAL

- (i) Bids must be on the official bid form, which shall be completed in all respects.
- (ii) Bids must be submitted in sealed envelopes.
- (iii) Separate envelopes must be used for each bid.
- (iv) No faxed bids will be accepted as confidentiality of price is not guaranteed.
- (v) The envelope must be addressed to the Department of Health, Edendale Hospital together with the bid number and closing date.
- (vi) The name and address of the quoting contractor must be endorsed on the back of the envelope.

- (vii) Contracts shall only be awarded to suppliers registered on the Provincial Suppliers Database.
- (viii) Bid documents must be deposited in the Bid box situated on the fourth floor.
- (ix) Bid documents will be available from Edendale Hospital, Private Bag X509, Plessislaer, 3216, Tel. (033) 395-4247, Stores Department, Receipts and Despatch Section, Room No. 10, between hours 08:00 and 15:00.
- (x) An original ZNT 30 form must be completed and submitted together with an original, valid Tax Clearance Certificate.
- (xi) All Departments of Health contracts awarded are subjected to appeals being timeously lodged (if any) and letters of acceptance being issued.

SUPPLY: Supply, delivery and installation of 1 x ventilator ICU, self contained.
 Bid Number: ZNB 39/11/07.
 Closing date: 2007-10-12 at 11h00.
 Enquiries: Mr L. Pillay, Tel. (033) 395-4306.
 Mrs R. Groenewald, Tel. (033) 395-4911.

BANKSETA

INVITATION TO BID

The BANKSETA is a statutory body established through the Skills Development Act of 1998 to enable its stakeholders to advance the national and global position of the banking and micro-finance industry.

The BANKSETA requires the services of an accredited service provider with the ability, capacity, experience and knowledge to conduct Life Long Learning workshops the National Credit Act to Small and Micro-Enterprises within the broader banking and micro-finance sector nationally.

Note: No briefing session will be held.

Please quote Reference No. B-0001568/01/08/004 in all correspondence. Correspondence without a reference number will not be attended to.

Bid documentation is available for downloading from the BANKSETA website (www.bankseta.org.za) or electronically, on request by e-mail, from Mary Morudu at mmorudu@deloitte.co.za (Soft copies of the bid documentation are available, for collection only, on prior request by telephone from Mary Morudu at (012) 482-0397.

The closing date for submissions is Monday, 21 January 2008 at 11:00. No late submissions will be considered.

Submissions should be delivered to: The Procurement Manager, BANKSETA, Thornhill Office Park, Building 15, 94 Bekker Road, Midrand.

Procurement process administered by Deloitte.

GAUTENG DEPARTMENT OF PUBLIC TRANSPORT, ROADS AND WORKS

T1.1 TENDER NOTICE AND INVITATION TO TENDER

THE DEPARTMENT OF PUBLIC TRANSPORT, ROADS AND WORKS INVITES TENDERS FOR:

TENDER No.	INSTITUTION	EVALUATION CRITERIA	COMPULSORY SITE MEETING	TENDER CLOSING
GC1730/ 10/2007	Electrical installation for the Frail Care Centre at Jameson Park	CIDB Level 6EE or higher 90:10 preferential point system Price = 60 points, Functionality = 30 points (labour intensity = 15 points and job creation = 15 points) Preference RDP Goals (10 pts) HDI = 4, Gender = 3, Disability = 1 and Youth = 2	<i>Venue:</i> Jameson Park at Clinic. <i>Date:</i> 29 November 2007. <i>Time:</i> 11h00	7 December 2007 at: Time: 11:00

The Department is committed to Broad Based Black Economic Empowerment Act, No. 53 of 2003, and the maximization of labour intensity on all construction projects. We adhere to all relevant Acts including the Black Economic Empowerment Act, No. 55 of 2003, Preferential Procurement Policy Framework Act, No. 5 of 2000, and Employment Equity Act, No. 55 of 1998.

Tender shall be awarded on the basis of a policy that work shall be fairly or equitably distributed amongst contractors/entities that had not been awarded contract previously.

The Preferential Point System that will be applicable will be 90:10.

The physical address for collection of tender documents during working hours after 08:00 and 15:00 from 16 November 2007:

41 Simmonds Street, Sage Life Building, 8th Floor, North Tower.

A non-refundable tender deposit of R50,00 payable in cash or by bank-guaranteed cheque made out in favour of the Department, payable between 08:30 and 15:00 at the following address is required on collection of tender documents: 41 Simmonds Street, Sage Life Building, 8th Floor, North Tower, Johannesburg.

Queries relating to the issues of these documents may be addressed to: Ms Rosinah Modoutse, Tel. (011) 355-9437.

Telegraphic, telephonic, telex, facsimile and late tenders will not be accepted. Tenders to be deposited at the tender box in the foyer of the Batho Pele Building, 91 Commissioner Street.

Requirements for sealing, addressing, delivery, opening and assessment of tenders are stated in the tender data.

GAUTENG DEPARTMENT OF PUBLIC TRANSPORT, ROADS AND WORKS

T1.1 TENDER NOTICE AND INVITATION TO TENDER

THE DEPARTMENT OF PUBLIC TRANSPORT, ROADS AND WORKS INVITES TENDERS FOR:

TENDER No.	SERVICE	EVALUATION CRITERIA	COMPULSORY SITE MEETING	TENDER CLOSING
GC 1739/10/2007	Specialist Proposal to Convert 16 ton coal fired steam boilers to Natural Gas Firing at Johannesburg Hospital Engineering and Construction Service	CIDB Level 5ME or higher 90:10 preferential point system Price = 60 points, Functionality = 30 points (labour intensity = 15 points and job creation = 15 points Preference RDP Goals (10 pts) HDI = 4, Gender = 3, Disability = 1 and Youth = 2	<i>Venue:</i> Helipad behind Johannesburg Hospital. <i>Date:</i> 19 November 2007. <i>Time:</i> 10h00	30 November 2007 at 11:00.
GC 1740/10/2007	Construction of Orlando Enterprise Development Centre on Erf 6518, in Orlando East, Soweto	CIDB Level 4GB or higher 90:10 preferential point system Price = 60 points, Functionality = 30 points (labour intensity = 15 points and job creation = 15 points Preference RDP Goals (10 pts) HDI = 4, Gender = 3, Disability = 1 and Youth = 2	<i>Venue:</i> Orlando Enterprise Development behind Orlando Police Station, 6518 Orlando, East Rathebe Street. <i>Date:</i> 27 November 2007. <i>Time:</i> 10:00	7 December 2007 at 11:00.
GC 1741/10/2007	New Thulani Development Centre on Stand 3206, Thulani Ext. 1	CIDB Level 5GB or higher 90:10 preferential point system Price = 60 points, Functionality = 30 points (labour intensity = 15 points and job creation = 15 points Preference RDP Goals (10 pts) HDI = 4, Gender = 3, Disability = 1 and Youth = 2	<i>Venue:</i> New Thulani Development Centre, Doornkop, Stand No. 3206, Extension 1, 56th Street <i>Date:</i> 29 November 2007. <i>Time:</i> 11:00	7 December 2007 at 11:00

The Department is committed to Broad Based Black Economic Empowerment Act, No. 53 of 2003, and the maximization of labour intensity on all construction projects. We adhere to all relevant Acts including the Black Economic Empowerment Act, No. 55 of 2003, Preferential Procurement Policy Framework Act, No. 5 of 2000, and Employment Equity Act, No. 55 of 1998.

Tenders shall be awarded on the basis of a policy that work shall be fairly or equitably distributed amongst contractors/entities that had not been awarded contract previously.

The Preferential Point System that will be applicable will be 90:10.

The physical address for collection of tender documents during working hours after 08:00 and 15:00 from 16 November 2007:

41 Simmonds Street, Sage Life Building, 8th Floor, North Tower.

A non-refundable tender deposit of R50,00 payable in cash or by bank-guaranteed cheque made out in favour of the Department, payable between 08:30 and 15:00 at the following address is required on collection of tender documents: 41 Simmonds Street, Sage Life Building, 8th Floor, North Tower, Johannesburg.

Queries relating to the issues of these documents may be addressed to: Ms Rosinah Modoutse, Tel. (011) 355-9437.

Telegraphic, telephonic, telex, facsimile and late tenders will not be accepted. Tenders to be deposited at the tender box in the foyer of the Batho Pele Building, 91 Commissioner Street.

Requirements for sealing, addressing, delivery, opening and assessment of tenders are stated in the tender data.

GAUTENG DEPARTMENT OF PUBLIC TRANSPORT, ROADS AND WORKS**T1.1 TENDER NOTICE AND INVITATION TO TENDER****THE DEPARTMENT OF PUBLIC TRANSPORT, ROADS AND WORKS INVITES TENDERS FOR:
RENOVATIONS AT WARD 24**

TENDER No.	INSTITUTION	SERVICE	PREFERENTIAL POINT SYSTEM	CIDB LEVEL	COMPULSORY BRIEFING SESSION	TENDER CLOSING
RFP02/11/2007TEAC	Mabopane DLTC and Motor City	Refurbishment of building	90:10 Price = 60 Functionality = 30 Youth = 2 HDI = 4 Disability = 2 SMME = 2	6 GB	22 November 2007 @ Mabopane DLTC and Motor City. <i>Time: 11:00</i>	7 December 2007. <i>Time: 11:00</i>

The Department is committed to Broad Based Black Economic Empowerment Act, No. 53 of 2003, and the maximization of labour intensity on all construction projects. We adhere to all relevant Acts including the Preferential Procurement Policy Framework Act, No. 5 of 2000, and Employment Equity Act, No. 55 of 1998.

The physical address for collection of tender documents during working hours after 08:00 and 15:00 from 12 October 2007 is 41 Simmonds Street, 8th Floor, North Tower Sage Life Building.

A non-refundable deposit of R50,00 payable in cash or by bank-guaranteed cheque made out in favour of the Department, payable between 08:30 and 15:00 at the above address is required on collection of tender documents:

Queries relating to the issues of these documents may be addressed to: Ms Mpumi Papiyana, Tel. (011) 355-9437.

Telegraphic, telephonic, telex, facsimile and late tenders will not be accepted. Tenders to be deposited at the tender box in the ground floor of 91 Commissioner Street, Bathopele Building, on or before the closing date.

Requirements for sealing, addressing, delivery, opening and assessment of tenders are stated in the tender documentation.

DEPARTMENT OF TRANSPORT: PROVINCE OF KWAZULU-NATAL**CONTRACT No. ZNT 373/A/P15-1/1/1907**

The Department of Transport, KwaZulu-Natal Provincial Government, invites tenders for the construction of Layerworks and Surfacing on Main Road P15-1 from km 15,3 to km 17,4.

Tenderers should have a CIDB contractor grading designation of 4CE PE or higher. Potentially emerging enterprises who satisfy criteria stated in the Tender Data may submit tender offers.

Tenderers must be registered with the CIDB in a Civil Engineering class of construction works. Tenderers must also be registered with the Department of Transport as a Stage 4 emerging contractor within the Vukuzakhe Contractor Development Programme (as per the database of the Department of Transport).

The physical address for collection of tender documents is: Department of Transport, B Block, Acquisition Section, KwaZulu-Natal Department of Transport, 172 Burger Street, Pietermaritzburg.

Documents may be collected during working hours (09h00 to 13h00 and 14h00 to 16h00) from Monday, 26 November 2007, and will also be available at the compulsory pre-tender meeting.

Technical enquiries relating to the issues of these documents may be addressed to:

Department of Transport: *Name:* W Bennett, Tel. (033) 845-5801. Fax (033) 394-8931. E-mail: Wally.Bennett@kzntransport.gov.za

Semenya Furumele Consulting (Pty) Ltd: *Name:* Raymond Reynolds, Tel. (031) 764-5293. Fax (031) 764-5294. E-mail: raymond.reynolds@sfte.co.za

A compulsory pre-tender meeting with representatives of the Employer will take place on site at the Woshi River Bridge on Main Road P15-1 on Friday, 30 November 2007 starting at 10h00.

The closing time for receipt of tenders is 11h00 on Friday, 4 January 2008.

Telegraphic, telephonic, telex, facsimile, electronic, e-mailed and late tenders will not be accepted.

Requirements for sealing, addressing, delivery, opening and assessment of tenders are stated in the Tender Data.

STATE INFORMATION TECHNOLOGY AGENCY (PTY) LTD (SITA)

SITA hereby invites bidders for the following bid: RFB-615

REQUEST FOR BID: FOR THE PROVISION OF VIDEO CONFERENCING SOLUTION

Printed copies of the Bid document will be available on the 23rd November 2007 and are obtainable from the Tender Office at SITA Head Office. A soft copy will be available on www.sita.co.za

Office hours: 08:00–12:00 and 13:00–16:00 (Monday to Friday).

Contact person: Bid Office Manager.

E-mail: tenders@sita.co.za

Bids must be deposited in SITA's bid box not later than 21st December 2007, 11:00 am (South African Time). The bid box is situated at the Main Gate of SITA Head Office: 459 Tsitsa Street, Erasmuskloof in Pretoria.

Please note that a standard submission fee of R200,00 (non-refundable and per Bid) is payable to:

Local Transfers:

Account Name: **SITA (PTY) LTD**

Bank: Standard

Account No.: 410298158

Branch No.: 012645

Branch Name: Centurion

Reference: Tender No.

International Transfers:

Account Name: **SITA (PTY) LTD**

Bank: Standard

Account No.: 410298158

Bank Sort Code: ZA 012645

Branch Name: Centurion

Swift Code: SBZAZAJJ

Reference: Tender No.

Non-compulsory briefing session will be held on the 30th November 2007. Venue: Erasmuskloof, Apollo auditorium at 10h00.

It is the prospective tenderer's responsibility to obtain documents in time so as to ensure that responses reach SITA (Pty) Ltd, timeously. SITA (Pty) Ltd, cannot be held responsible for a delay in the postal service. SITA (Pty) Ltd SA Ltd reserves the right to cancel or withdraw any item published.

MERSETA

LEADERS IN CLOSING THE SKILLS GAP

Service: Conduct a research study to quantify the extent of illiteracy in the manufacturing, engineering and related services sub-sectors, collect data on ABET, provisioning in these sub-sectors by small, medium and large companies irrespective of funding source; and advise on the ability of learners who successfully complete ABET learning programmes at ABET level 4 to access further learning and/or career advancement opportunities.

Documents available from: Terms of Reference (ToR) available from: Projects Division: Merseta, 3rd Floor, Metropolitan Park Building, 8 Hillside Road, Parktown. (011) 484-9310 or www.merseta.org.za Documents/Tenders.

Closing date: 12h00, Monday, 10 December 2007.

INDEPENDENT COMMUNICATIONS AUTHORITY OF SOUTH AFRICA (ICASA)

ICASA HEREBY INVITES BIDDERS FOR THE FOLLOWING BID:

Competitive bidding process: Appointment of a service provider to determine the condition and residual values of Assets for the Independent Communications Authority of South Africa (ICASA) on the 80/20 Preferential Procurement Principle Framework Act of 2000—**Bid Number: ICASA 45/2007**

Hard copies of the bid document will be available on Friday, 23 November 2007, bid documents are obtainable at ICASA, 164 Katherine Street, Pin Mill Farm Block B, Sandton. A soft copy of the bid document will be available on the ICASA website www.icasa.org.za

Office hours: 08:30–16:30 (Monday to Friday).

Contact person: Mr Kgosi Phoi, Fax (011) 321-8274. E-mail: kphoi@icasa.org.za

Bids must be deposited in ICASA's bid box on or before Tuesday, 11 December 2007 and not later than 11:00 am (South African Time). The bid box is situated at the reception area of ICASA Head Office at 164 Katherine Street, Pin Mill Farm Block B, Sandton, and Johannesburg.

NB: It is the prospective bidders' responsibility to obtain documents in time so as to ensure that responses reach ICASA, timeously. ICASA cannot be held responsible for delays in the postal service.

ICASA reserves the right to cancel or withdrawn any item published on this bid.

DEPARTMENT OF HEALTH

MANGUZI HOSPITAL

QUOTATIONS ARE INVITED FOR THE UNDERMENTIONED REQUIREMENTS OF NATIONAL TENDER BULLETIN

- (i) Quotations must be on an official quotation form, which shall be completed in all respects and all information must be supplied as stipulated in the quotation document.
- (ii) Quotations must be submitted in sealed envelopes.

- (iii) Separate envelopes must be used for each quotation.
- (iv) The envelope/s must be addressed to the Department of Health: Manguzi Hospital with the quotation number and the closing date.
- (v) The name and the address of the quoting contractors must be endorsed at the back of the envelope(s).
- (vi) All Departments of Health Contractors awarded are subject to appeals being timeously lodged (if any) and letters of acceptance being issued.
- (vii) Quotation forms or documents are available from Manguzi Hospital, off Main Road, Ithala Centre, Manguzi Town, Kwa-ngwanase, 3973.
- (viii) For quotations exceeding R30 000,00 an original ZNT 30 application for Preference point forms must be submitted with the quotation.
- (ix) An original recent Tax Clearance Certificate must accompany the quote regardless of the price.

SERVICE:

Manguzi Hospital Human Resource Department is looking for training service providers who are accredited and registered with SAQA (PSETA & HWESETA) to provide the training on the following programmes or courses: **Presiding and investigating course** and the targeted group falls under NQF level 4 and above, which includes the following Managers, Professionals, Technical and trade workers, Clerical and Admin workers. The facilitator must be knowledgeable in both English and Zulu. Learning material and certificate issuing will be the tenderer's responsibility.

Duration of the course:	3 days.
No. of candidates:	25 candidates
Quotation number:	ZNQ 862/07-08.
Closing date:	03/12/2007.
Closing time:	11:00.
Contact person:	Ms Sthembile Mkhonto, Tel. (035) 592-0150 Ext. 212.
Contact person regarding specifications:	Ms L.F. Nsele, Tel. (035) 592-0150 Ext. 171.

SERVICE:

Manguzi Hospital Human Resource Department is looking for training service providers who are accredited and registered with SAQA (PSETA & HWESETA) to conduct the training on the following programmes or courses: **Minutes taking** and the targeted group falls under NQF level 4 and above, which includes the following Professionals, Technical and trade workers, Community and Personnel service, Clerical and Admin workers. The facilitator must be knowledgeable in both English and Zulu. Learning material and certificate issuing will be the tenderer's responsibility.

Duration of the course:	2 days.
No. of candidates:	15 candidates.
Quotation number:	ZNQ 863/07-08.
Closing date:	03/12/2007.
Closing time:	11:00.
Contact person:	Ms Sthembile Mkhonto, Tel. (035) 592-0150 Ext. 212.
Contact person regarding specifications:	Ms L.F. Nsele, Tel. (035) 592-0150 Ext. 171.

DEPARTMENT OF HEALTH

CENTRAL SUPPLY CHAIN MANAGEMENT DIRECTORATE

BIDS ARE INVITED FOR THE UNDERMENTIONED REQUIREMENTS OF THE PROVINCIAL ADMINISTRATION OF KWAZULU-NATAL

- (i) Submissions must be on the official bid form, which shall be completed in all respects, and all information must be supplied.
- (ii) Bids must be submitted in sealed envelopes.
- (iii) The envelope must be addressed to Central Supply Chain Management together with the bid number and closing date.
- (iv) The name and address of the bidder must be endorsed on the back of the envelope.
- (v) All Department of Health Contracts awarded are subject to appeals being timeously lodged (if any) and letters of acceptance being issued.
- (vi) Bid documents are available from Central Supply Chain Management, Capital Towers, First Floor, 121 Chief Albert Luthuli Street, Pietermaritzburg.

INVITATION OF QUOTATIONS

SUPPLY: Supply of furniture: Budget & SCM.
 Bid number: ZNQ 1201 CSCM/07/08.
 Closing date: 2007-12-04.
 Closing time: 11:00.
 Contact person: Mrs N. Mbongwa, Tel. (033) 846-7394.
 Enquiries regarding specifications: T Beaumont, Tel. (033) 846-7383.

DEPARTMENT OF PUBLIC WORKS**SOUTHERN REGIONAL OFFICE****INVITATION TO BIDS****AMENDED VENUES FOR SITE INSPECTION MEETINGS**

- (i) Bids may only be submitted on the official tender form, which shall be completed in all respects and all information must be supplied as stipulated in the bid documents.
- (ii) Requirements for sealing, addressing, delivery, opening and assessment of tenders are stated in the tender data.
- (iii) Telephonic, facsimile and late tenders will not be accepted.
- (iv) All tenderers must be registered on the Provincial Suppliers database and the CIDB.

SERVICE: Highflats: Indlelehle High School: Electrical installation.
 CIDB grading: 1 EE.
 Bid number: ZNTM00216W.
 Closing date: 2007-12-14.
 Closing time: 11:00.
 Compulsory site inspection meeting:
 Date: 2007-11-29.
 Time: 12:00.
 Venue: Tenderers to meet at Engen Garage in Highflats.
 Technical queries: Mr W. Gerber, Tel. (039) 682-2316.

SERVICE: Dududu: Qiko High School: Electrical Installation.
 CIDB grading: 2EE.
 Bid number: ZNTM00181W.
 Closing date: 2007-12-14.
 Closing time: 11:00.
 Compulsory site inspection meeting:
 Date: 2007-11-27.
 Time: 9:30.
 Venue: Tenderers to meet at Vulamehlo Welfare Offices.
 Technical queries: Mr W. Gerber, Tel. (039) 682-2316.

SERVICE: Mantulela Combined Primary School: Electrical installation.
 CIDB grading: 2EE.
 Bid number: ZNTM00217W.
 Closing date: 2007-12-14.
 Closing time: 11:00.
 Compulsory site inspection meeting:
 Date: 2007-11-29.
 Time: 9:30.
 Venue: Tenderers to meet at Engen Garage in Highflats.
 Technical queries: Mr W. Gerber, Tel. (039) 682-2316.

SERVICE: Dududu: Siphephile High School: Electrical installation.
 CIDB grading: 2EE.
 Bid number: ZNTM00218W.
 Closing date: 2007-12-14.
 Closing time: 11:00.
 Compulsory site inspection meeting:
 Date: 2007-11-27.
 Time: 11:00.
 Venue: Tenderers to meet at Vulamehlo Welfare Offices.
 Technical queries: Mr W. Gerber, Tel. (039) 682-2316.

SERVICE:	Pietermaritzburg: Nobanda Junior Primary School: Repairs and renovations.
CIDB grading:	4 GB or if a joint venture 3 x 3 GB.
Bid number:	ZNTM00198W.
Closing date:	2007-12-14.
Closing time:	11:00.
Compulsory site inspection meeting:	
Date:	2007-11-28.
Time:	11:00.
Venue:	Tenderers to meet at Nobanda Junior Primary School.
Technical queries:	Mr W Butland, Tel. (033) 355-7100.
Above documents available from:	Department of Works, Umgungundlovu District Office, 10-18 Prince Alfred Street Extension, Pietermaritzburg.
Contact person:	Ms G. Ncanana, Tel. (033) 355-7234.

DEPARTMENT OF HEALTH

TONGAAT COMMUNITY HEALTH CENTRE

BIDS ARE INVITED FOR THE UNDERMENTIONED REQUIREMENTS OF THE PROVINCIAL ADMINISTRATION OF KWAZULU-NATAL

- (i) Bids must be on the official bid quotation form, which shall be completed in all respects, and all information must be supplied as stipulated in the bids.
- (ii) Bids must be submitted in sealed envelopes.
- (iii) Separate envelopes must be used for each bid.
- (iv) The envelopes must be addressed to Department of Health Tongaat Community Health Centre for the attention of Ms Lindiwe Magwaza reflecting the bid number.
- (v) The name and address of the bidding company must be endorsed at the back of the envelope. All Department of Health contracts awarded are subject to appeals being timeously lodged (if any) and letters of acceptance being issued.
- (vi) Please complete original ZNT 30 documents when submitting bids together with tax clearance certificate.
- (vii) Bids documents are available from Tongaat Community Health Centre, Acquisition Section, Dores Lane Street, Tel. (032) 944-5054. Fax. (032) 945-1210.

RE-ADVERTISEMENT

SUPPLY:	Sphygmomanometer electronic NIBP machine and SpO ₂ without pleth waveform display X3 (H.T.S. specification No. E69).
Bid number:	ZNQ 589/2007.
Closing date:	30 November 2007.
Closing time:	11:00.
Contact person:	Lindiwe Magwaza, Tel. (032) 944-5054.
Enquiries regarding specification:	Sthembiso Zondi, Tel. (032) 944-5054.

DEPARTMENT OF LOCAL GOVERNMENT AND TRADITIONAL AFFAIRS

- (i) Bids must be on the official bid form which shall be completed in all respects, and all information must be supplied as stipulated in the bid document.
- (ii) Bids must be submitted in separate sealed envelopes.
- (iii) Bids must be addressed as directed in the Bid Document, i.e. front of the envelope must reflect the bid number, description of bid, closing date and time as well as the name and address of the bidder. The name and address of the Department must be written on the reverse side of the envelope.

Re: AMENDMENTS

SERVICE:	Appointment of the service provider to Conduct External Evaluation of Departmental Process and Programmes.
Bid number:	ZNT 1513/2007 LG.
Closing date:	13 December 2007.
Time:	11h00.
Documents available:	Bid Office, Office 08, 13th Floor, Natalia Building, 330 Langalibalele Street, Pietermaritzburg.
Contact person:	Mr Brian Mathebula, Tel: (033) 395-2573.

Compulsory briefing session:

Date: 30 November 2007.
 Time: 10:00 am.
 Venue: 7th Floor, Main Boardroom, Southern Life Plaza, 271 Church Street.

Note: Bid documents are to be collected at the address stipulated before the date of the compulsory briefing session. No documents will be handed out at the briefing session. Persons who do not have the documents before the briefing session will be disqualified from submitting bids.

ADDENDUM OF TENDER**DEPARTMENT OF PUBLIC WORKS, REPUBLIC OF SOUTH AFRICA**

Documents obtainable from Department of Public Works, Government Offices, corner of Aliwal and West Streets, Durban.

Contact person: Ms Tshidi Sibiyi, Room No. 11, Tel: (031) 314-7079/(031) 314-7160. Fax (031) 332-5853. E-mail: tshidi.sibiyi@dpw.gov.za

Bid/Tender No. DR07/1146.

The above tender was advertised on the 16/11/2007 with two projects as nominated sub-contracts. Please be advised that those contracts have since been separated into two different contracts with two different tender numbers as stated below. Please note that DR07/1146 will remain the same as advertised.

Bid/Tender No. DR07/1147.

Golela Border Post: SAPS: Freight Handling Building: Nominated sub-contract CIDB contractor grading designation required: 7 GB or higher.

Potentially emerging enterprises: 6 GB PE.

The requirements in respect of 80/20 or 90/10 preference point scoring system as reflected in clause F3.11 of the tender data will apply and the points reflected below for preferences will be adjusted accordingly on the pro-rata basis if required.

Preference:		Price	
HDI	5 points	Price	100% (of 90)
Woman	3 points	Quality/Functionality:	
Disabled	2 points		
Other:	0 points		
Total must equal:	10 points	Total must equal:	100% (of 90)

Compulsory site inspection: Date: 30/11/2007. Time: 10:00 am. Venue: Golela Border Post: SAPS.

Documents will be sold at a non-refundable deposit of R200,00.

Bid/Tender No. DR07/1148.

Golela Border Post: SAPS: State Warehousing Sub-station, incinator building, carpots and garages: Nominated sub-contract:

CIDB contractor grading designation required: 7 GB or higher.

Potentially emerging enterprises: 6 GB PE.

The requirements in respect of 80/20 or 90/10 preference point scoring system as reflected in clause F3.11 of the tender data will apply and the points reflected below for preferences will be adjusted accordingly on the pro-rata basis if required.

Preference:		Price	
HDI	5 points	Price	100% (of 90)
Woman	3 points	Quality/Functionality:	
Disabled	2 points		
Other:	0 points		
Total must equal:	10 points	Total must equal:	100% (of 90)

Compulsory site inspection: Date: 30/11/2007. Time: 10:00 am. Venue: Golela Border Post: SAPS.

Documents will be sold at a non-refundable deposit of R200,00.

BUSINESS HOURS: 08h00–12h00 and 13h30–15h00.

Please note that only contractors who can supply proof of Income Tax reference number VAT Registration Number, Company Registration, CIDB Registration need apply. All interested contractors must submit their original Tax Clearance Certificate together with the tender documents on the closing date. If the said certificate is not attached, the tender will be regarded as invalid. Please be advised that only cash or bank-guaranteed cheques will be accepted when purchasing tender documents.

CLOSING DATE: 12 December 2007.

B. RESULTS OF TENDER INVITATIONS

Notices are not sent to unsuccessful tenderers, but particulars of successful tenderers are published hereunder for general information:

SUPPLIES**DEPARTMENT OF HEALTH: GREYS PROVINCIAL HOSPITAL**

QUOTATION No.	DESCRIPTION	CONTRACTOR
ZNQ 56/09/07	Analyser Middle Ear	Batho Kopanang Distributors (Pty) Ltd

DEPARTMENT OF HEALTH: KWAZULU-NATAL: BENEDICTINE HOSPITAL

QUOTATION No.	DESCRIPTION	CONTRACTOR
ZNQ 35/2007-2008	N.I.B.P. monitor (machine)	Duromed CC
ZNQ 42/2007-2008	Portable O2 saturation monitor	Duromed CC

DEPARTMENT OF HEALTH: INFRASTRUCTURE DEVELOPMENT SUB-DIRECTORATE (CAPSO/REAL ESTATE)

QUOTATION No.	DESCRIPTION	CONTRACTOR
ZNB08.07/08-H	Letting of Tuckshop as a trading facility at Phoenix CHC	Sethu Zethu Trading CC

DEPARTMENT OF HEALTH: KWAZULU-NATAL: DUNDEE PROVINCIAL HOSPITAL: SUPPLY CHAIN MANAGEMENT

BID No.	DESCRIPTION	CONTRACTOR
ZNQDD09/07/2007	Fruit & vegetables for 6 months	Asibonke Konke Trading Enterprise

DEPARTMENT OF HEALTH: KWAZULU-NATAL: PROVINCIAL MEDICAL SUPPLY CENTRE

QUOTATION No.	DESCRIPTION	CONTRACTOR
ZNQ 13/08/2007	Green PVC tape	Rayvin Trading
ZNQ 10/08/2007	Hyster training	Eskilz
ZNQ 13/07/2007	Stationery—Equipment	Kloof Stationers
ZNQ 15/08/2007	Ice packs	Oshlanga Enterprises

GAUTENG SHARED SERVICE CENTRE

QUOTATION No.	DESCRIPTION	SUCCESSFUL SUPPLIERS
GT/GSSC/35/2007	Award of the request for the following proposal: Supply and delivery of duplicator paper. <i>Contact person: Miss Lindiwe Hlatshwayo, Tel. (011) 689-6127</i>	Shaneal Distributors; Thuthlani Paper (Pty) Ltd and Tirisano Paper & Stationery. Various institutions.

DEPARTMENT OF HEALTH

TENDER No.	DESCRIPTION	SUCCESSFUL TENDERER
GT/GHD/58/2006 MC	Supply of syringes, needles and blood letting devices	<ol style="list-style-type: none"> 1. Unitrade 1032 CC. 2. PanAvest Health Group. 3. Grobir Medical Suppliers CC. 4. Lechoba Medicals (Pty) Ltd. 5. Bathathe Business Entreprises. 6. Golden Falls Medical. 7. Biovac SA (Pty) Ltd. 8. Futuremed Pharmaceuticals (Pty) Ltd. 9. Omnimed (Pty) Ltd. 10. Adcock Ingram Critical (Pty) Ltd. 11. Techno Med CC. 12. Multisurge CC. 13. Myriad Medical (Pty) Ltd. 14. Palmed Medical and Surgical Supplies CC. 15. Creative Health Risk Management. 16. Viking Medical and Surgical (Pty) Ltd.

DEPARTMENT OF HEALTH: KWAZULU-NATAL: BENEDICTINE CAMPUS

QUOTATION No.	DESCRIPTION	SUPPLIER
111/2007/10/03	1 x boardroom table—oval, 3 500 x 1 600—12 seater cherry colour 20 x curve C41W—Synchro high back with 3 forward fit 1 x conference table—round, 50 mm top solid edge dome, base 1 200 dia 4 seater—cherry	Cyrotek CC
112/2007/10/03	2 x bassinets 1 x percussor/patella hammer 1 x washing basin—large size 1 x oxygen cylinder with a gauge 1 x drug cupboard	Healthware CC

QUOTATION No.	DESCRIPTION	SUPPLIER
112/2007/10/03	2 x feeding pump	Umsinsi Maintenance & Supplies
112/2007/10/03	1 x baby bath unit with basin and slab	Meditek-hemco
113/2007/10/03	1 x laryngoscope 1 x otoscope/auroscope 1 x ophthalmoscope 1 x adult scale—to measure height as well 2 x flashlight/penlight 1 x dressing trolley	Alpha Healthcare and Equipment CC
114/2007/10/03	1 x haemoglucotest machine 1 x flowmeter machine 1 x baby/paediatric scale 1 x doll with orifices 1 x baby doll—without placenta 1 x emergency trolley	Duromed CC
115/2007/10/03	1 x dynamap 1 x sthetoscope 1 x suction machine 24 x electronic/digital thermometers 1 x resuscitation doll	Duromed
115/2007/10/03	1 x baumanometer	Kolmed Medical & Surgical Supplies

DEPARTMENT OF HEALTH: KWAZULU-NATAL: PORT SHEPSTONE PROVINCIAL HOSPITAL

BID No.	DESCRIPTION	SUPPLIER
ZNQ G34 of 2006/07	Cleaning Service at Port Shepstone Mobile Clinic. <i>Contact person: Mr S. Premnadu, Tel. (039) 688-6120</i>	Nombulula Co-Operative Limited
ZNQ G01 of 2007/08	Phambili Hospital Products (Pty) Ltd. <i>Contact person: Mr S. Premnadu, Tel. (039) 688-6120</i>	Phambili Hospital Products (Pty) Ltd
ZNQ G03 of 2007/08	3 x Pots Cooking Oil Jacketed—Gas 1351. <i>Contact person: Mr S. Premnadu, Tel. (039) 688-6120</i>	Zululand Steam
ZNQ G11 of 2007/08	1 x Electric Tow Tractor with Trailer. <i>Contact person: Mr S. Premnadu, Tel. (039) 688-6120</i>	Nomageba Trading
ZNQ G25 of 2006/07	1 x Ventilator Neonatal/Paediatric ICU. <i>Contact person: Mr S. Premnadu, Tel. (039) 688-6120</i>	Respiratory Care Africa (Avea Std)

SOUTH AFRICAN POLICE SERVICES

TENDER No.	DESCRIPTION	CONTRACTORS
Q19/1/9/1/212TT (06)	Results of tender for: Manufacture, supply and delivery of female bullet resistant vests for the South African Police Service in accordance with the SAPS Specification SAPS 2261/06	Closed on 2007-07-10. Bid Item 1.1 to 1.8 was awarded to the company Fields Wear CC to a value of R21 024 585,00 (vat included) and Item 2.1 to 2.2 was awarded to Bullet Proofing Technology to a value of R11 263 815,29 (vat included)

DEPARTMENT OF ARTS AND CULTURE

BID No.	DESCRIPTION	SUCCESSFUL BIDDER	PRICE	PREFERENCE CLAIMED
DAC/0008/07/T	Appointment of an events company to commemorate the 90th Anniversary of the SS Mendi Tragedy	Out of the Box Productions	R3 910,334,52	HDI equity ownership: 0% Women equity: 0% Disability: 0%

DEPARTMENT OF AGRICULTURE

BID No.	DESCRIPTION	SUCCESSFUL BIDDER	PRICE	PREFERENCE CLAIMED
4.4.12.4/4/07	The supply and delivery of (150–175 mm) hardwood 2,7 m fencing poles for a period of one year	Senwes Limited	R362 040,00/total price (R120,68/ per each x 3 000 estimated quantity) firm	HDI equity ownership: 27,1% Women equity ownership: 27,1% Disability equity ownership: 27,1%

BID No.	DESCRIPTION	SUCCESSFUL BIDDER	PRICE	PREFERENCE CLAIMED
4.4.12.4/3/07	The supply and delivery of (32–58 mm) 1,8 m round hardwood droppers for a period of one year	FS Drake t/a Diggers Rest Farm	R5,88/total price, per each, firm (R5,88 x 75 060 estimated quantity = R441 352,80)	HDI equity ownership: 0% Women equity ownership: 50% Disability equity ownership: 0%

DEPARTMENT OF HEALTH: KWAZULU-NATAL: ADDINGTON HOSPITAL

TENDER No.	DESCRIPTION	SUCCESSFUL BIDDER	PRICE
ZNQ 304/07	Sphygmomanometers	Welch Allyn	—

DEPARTMENT OF AGRICULTURE AND ENVIRONMENTAL AFFAIRS: KWAZULU-NATAL

BID No.	DESCRIPTION	CONTRACTOR
ZNB3501/07A	Planting of dry beans at Umkhanyakude: Ndumo B	Bethlice Projects
ZNB3503/07A	Planting of dry beans at Amajuba	Bethlice (Dixie Bay)—Eastborne Project Nanini 241 CC—Dicks Bethlice (Dixie Bay)—Ennis Bethlice (Dixie Bay)—Inkosingizima Thulagric Trading—Kingsley Thulagric Trading—Waihoek
ZNB3504/07A	Planting of dry beans at Uthukela: Imbabazane	Sokotshane Forestry Construction
ZNB3505/07A	Planting of beans at Uthukela: Ukhahlamba	Sokotshane Forestry Construction

DEPARTMENT OF HEALTH: MANGUZI HOSPITAL

QUOTATION No.	DESCRIPTION	CONTRACTOR
ZNQ 507/07-08	28 x supply and install Forwin curtain rails, complete set. Measurements: 2,360 m x 1,270 m 28 x supply and install chintz no. 155cz wash woven with 100% polyester yarn curtains, measurements 3,360 m x 2,400 m	Z3 Investments
ZNQ 261/07-08	1 Unit x Electrosurgical unit (HTS Specification)	Energy X-ray Trading
ZNQ 291/07-08	1 Unit x Nerve Block Monitor, Stimulators, H.T.S. Specification	Delta Surgical CC
ZNQ 494/07-08	1 Unit x CTG Machine with probes H.T.S., H.T.S. Specification	Glenmed Medical

SERVICE**DEPARTMENT OF WORKS: MIDLANDS REGION**

BID No.	DESCRIPTION	CONTRACTOR
ZNT L00502 W	Ladysmith Regional Office: Supply and deliver 2 office park homes	D & C Mobile Home Enterprises CC, t/a Natal Parkhomes

DEPARTMENT OF WORKS: NKONJENI HOSPITAL

BID No.	DESCRIPTION	CONTRACTOR
ZNQ 767/07	Cardiotocographic—ctg machine	R & J Medical Suppliers
ZNQ 287/07	Supply and install carparks	Thulamabuka Construction & Projects

DEPARTMENT OF HEALTH: CENTRAL SUPPLY CHAIN MANAGEMENT DIRECTORATE

BID No.	DESCRIPTION	CONTRACTOR
ZNB 7683/2006-H	Supply of 1 Digital Mid-Range colour doppler: King Edward VIII Hospital	G W Strike t/a Glenmed

GAUTENG SHARED SERVICE CENTRE

BID No.	DESCRIPTION	CONTRACTOR
GT/GSSC/54/2007	Rendering of Canteen, Coffe Shop and Bar Services for GSSC. <i>Enquiries: A. Takalani, (011) 689-8850</i>	Shivava Trading CC

DEPARTMENT OF HEALTH: KWAZULU-NATAL: LOWER UMFOLOZI DISTRICT WAR MEMORIAL HOSPITAL

QUOTATION No.	DESCRIPTION	CONTRACTOR
ZNQ 852/2007/08	Washed peas coal	Mlina's Trading
ZNQ 1224/2007/08	Project management for 20 supervisors	Business Studies Unit/DUT

DEPARTMENT OF TRANSPORT: KWAZULU-NATAL

BID No.	DESCRIPTION	CONTRACTOR
ZNT 373T/ A/D168/1056	Construction of bulk earthworks and cross drainage on D168 from km 5,4 to km 8,0	MN Maphumulo Construction CC, t/a Zwelonke
ZNT 373 T/A/399/4008	The construction of mass earthworks and pavement layers comprising G9 selected subgrade G7 selected subgrade 4C Stabilised Subbase g1 base V drains subsoil drains kerb and channel on main road P399 from km 23,700 to km 24,940	Rob Business Enterprises
ZNT 2232T	Construction of earthworks, layerworks, drainage and retaining structures on Main Road 100, Ndwedwe km 26,540 to km 29,400	Afriscan Construction/TBA Construction/Amangcobo Construction JV

BANKSETA

BID No.	DESCRIPTION	SUCCESSFUL BIDDER	CONTRACT PRICE	PREFERENCE CLAIMED
B-0001661/ 01/08/001	Lifelong Learning Workshops on Disability	Gauge Architecture in consortium with Gauge Consulting	R60 648	Total HDI: 3.57 Total SMME: 2.09
B-0001568/ 01/08/002	Lifelong Learning Workshops on Strategy	Institute of Bankers in South Africa	R249 352,20	Total HDI: 0.00 Total SMME: 10.00
B-0001568/ 01/08/003	Lifelong Learning Workshops on Innovation	Pure Innovation	R110 010	Total HDI: 13.20 Total SMME: 3.50
B-0001661/ 01/08/002	Lifelong Learning Workshops on Performance Management	Institute of Bankers in South Africa	R167 152,50	Total HDI: 0.00 Total SMME: 2.50
B-0001661/ 01/08/003	Lifelong Learning Workshops on Corporate Governance	Institute of Bankers in South Africa	R167 152,50	Total HDI: 0.00 Total SMME: 2.50
B-0001253/ 01/07/001	FET College Support Project (New Venture Creation)	Insight Strategies	R178 296	Total HDI: 0.00 Total SMME: 3.00
B-0001628/ 01/08/005	External Moderation: Core and Elective Unit Standards	Assessment College of SA (Pty) Ltd	R225 000	Total HDI: 2.96 Total SMME: 7.00
B-0001660/ 01/08/003	Bridging Programme for People with Disabilities	Triple E Training Holdings	R254 160	Total HDI: 0.80 Total SMME: 0.00
B-0001754/08	Customer Satisfaction Survey	TMS Research	R299 250	Total HDI: 3.15 Total SMME: 2.50
B-0001701/ 01/08/003	Career Awareness Workshops	MMS Management Solutions	R350 000	Total HDI: 12.00 Total SMME: 1.50
B-0001604/ 01/08	Micro-Finance Skills Survey in the Broader Banking and Micro-Finance Sector, 2007	Kheta Consulting in consortium with Compuscan	R598 440,15	Total HDI: 0.88 Total SMME: 1.98
B-0001580/ 01/08/002	Research Project on Future Skills in Banking Sector	KNC & Associates	R641 364	Total HDI: 0.00 Total SMME: 1.00

NATIONAL TREASURY

BID No.	DESCRIPTION	CONTRACTOR
NT 001/07	Appointment of a panel of professional service providers (PSPS) for Neighbourhood Development Programme (Ndp) Unit for a period of (3) three years.	Tender has been finalised and awarded to 74 service providers
NT 005/07	Appointment of a recruitment advertisement agency for a period of three (3) years.	Bid has been finalised and awarded to Saatchi & Saatchi Recruitment Services Advertising and Jobvest (Pty) Ltd
NT 008/07	Appointment of a panel of professional service providers that will include Limited International Expertise so that TAU may continue to provide a rapid response facility to client Departments for a period of three (3) years	Bid has been finalised and awarded to 60 service providers
NT 010/07	The engagement of a rapid response team to support the National Department of Transport and host cities in finalising 2010 FIFA world cup transport projects	Bid has been finalised and awarded to Snavelavice Joint Venture
NT 009/07	Rendering of security services for the National Treasury Buildings, 240 Vermeulen Street, 40 Church Square and 3rd Floor of the Sita Building, Centurion, for the period of three (3) years	Bid has been finalised and awarded to G4S Security Services (SA) (Pty) Ltd

DEPARTMENT OF MINERALS AND ENERGY

BID No.	DESCRIPTION	CONTRACTOR
ME-636	Re-appointment of a travel management company for the Department of Minerals and Energy for the period of 2 years. <i>Enquiries:</i> Bongwiwe Sithembile, Tel. (012) 317-8744. Fax (012) 320-8716	Bid has been finalized and awarded to Travel With Flair (Pty) Ltd & Magic Travel Pty (Ltd)
ME-645	Re-appointment of contractor for the vegetation and fencing at Corheim Mine a derelict and ownerless asbestos mine located in the Northern Province. <i>Enquiries:</i> Bongwiwe Sithembile, Tel. (012) 317-8744	Bid has been finalized and awarded to Turbo Max for the amount of R1 239 713,41
ME-643	Re-appointment for the Development or Acquisition of a National Energy Database and Information System (NEDIS). <i>Enquiries:</i> Bongwiwe Sithembile, Tel. (012) 317-8744. Fax (012) 320-8716	Bid has been closed and not awarded
ME-646	Re-appointment of a contractor for the revegetation and fencing of the rehabilitated Asbes Asbestos Mine located in the Northern Cape. <i>Enquiries:</i> Bongwiwe Sithembile, Tel. (012) 317-8744. Fax (012) 320-8716	Bid has been finalized and awarded to Xosungula for the amount of R1 644 899,96
ME-647	Re-appointment of a contractor for the revegetation and fencing of the rehabilitated Hartland Asbestos Mine located in the Northern Cape. <i>Enquiries:</i> Bongwiwe Sithembile, Tel. (012) 317-8744. Fax (012) 320-8716	Bid has been finalized and awarded to R1 072 738,81

DEPARTMENT OF TRANSPORT: KWAZULU-NATAL

BID No.	DESCRIPTION	CONTRACTOR
ZNB 1146/07T	Security services at the Department of Transport Head Office Complex and 224 Prince Alfred Street, Pietermaritzburg	Socaca Trading Enterprise

SOUTH AFRICAN WEATHER SERVICE

BID No.	DESCRIPTION	SUCCESSFUL BIDDER
SAWS-0114	Cleaning service for the head office of SAWS for a period of 36 months	Hand to Hand Cleaners
SAWS-0115	Security service for the head office of SAWS for a period of 36 months	Eldna Security
SAWS-0116	Appointment of a panel of 3 travel agents for SAWS for a period of 36 months	Travel with Flair, Rennies Travel, HRG Connex Travel

C. TENDER INVITATIONS FINALISED

The following tenders have been finalised recently but only the reference numbers are published. Results will be furnished on request:

FMA 0015/07	NT 009/07	NT 008/07	NT 005/07	NT 001/07
-------------	-----------	-----------	-----------	-----------

D. TENDER INVITATIONS CANCELLED

GT/GSSC/13/2007	ZNQ 1521/07	4.4.12.2/28/07 (WITHDRAWN)	DPE 05/2007-2008
ZNQDD09/07/2007(CANCELLATION OF AWARD OF BID	674-2007/2008	4.4.12.2/10/07	DRA 04/2007
4.4.12.4/37/07	682-2007/2008	4.4.12.4/28/07	HLS 2/2007
ZNQ 1519/07	686-2007/2008	ZNQ 17/10/2007	DOT/09/2007/TP&IM
ZNQ 1520/07	691-2007/2008	GT/GDH/27/2007	
	692-2007/2008	GT/GDCS/65/2007	

Tenderers are invited to direct tender enquiries regarding the award of tenders to the relevant department/organisation that issued the tender. See the address list (Annexure 1 of the Government Tender Bulletin) for the relevant information.

**Any complaints on the State tendering system can be lodged with the Public Protector, Mr Mabedla Lawrence Mushwana, at the following address:
Private Bag X677,
Pretoria, 0001.
Tel: (012) 366-7000**

ANNEXURE 1

ADDRESS LIST

- 1 For collection of tender documents:** The Chief Director: Contract Management, Tender Information Centre, 240 Vermeulen Street, (Ground Floor), behind ABSA Bank (corner Andries and Vermeulen Streets), Pretoria.
Enquiries: Tel.: (012) 315-5732 or 315-5731 or 315-5858; Fax: (012) 315-5734.
Web address: www.treasury.gov.za. **Electronic tenders:** www.globalerfx.com
Closing address of tenders: The Chief Director: Contract Management, Tender Information Centre, 240 Vermeulen Street (Ground Floor), behind ABSA Bank (corner Andries and Vermeulen Streets), Pretoria.
Postal address: Private Bag X49, Pretoria, 0001.
Contact with Contract Management: The Chief Director: Contract Management, 240 Vermeulen Street (corner of Andries and Vermeulen Streets), Pretoria.
Office hours: 07:30–12:30 and 13:15–16:00 (Mondays to Fridays).
-
- 2** The Director-General: Public Works (Head Office), Private Bag X65, Pretoria, 0001 or Room 503, Fifth Floor, Central Government Offices, corner of Bosman and Vermeulen Streets, Pretoria.
Enquiries: Ms E. P. Odendaal/Mr J. M. Nkambule **Office hours:** 07:30–12:45 and 13:30–15:30
 Tel. (012) 337-2179/2167, Fax (012) 321-1575 Mondays to Fridays
-
- 3** Department of Public Works (Cape Town), Room 942, Ninth Floor, Lower Heerengracht, Customs Building, Foreshore, Cape Town, or Private Bag X9027, Cape Town, 8000; or deposited in the tender box in the main entrance, Ground Floor, Lower Heerengracht, Customs Building, Cape Town.
Enquiries: Miss Mouton/Ms Ndamane **Office hours:** 07:30–12:45 and 13:30–15:30
 Tel. (021) 402-2076/7, Fax (021) 419-6086 Mondays to Fridays
 E-mail: riana.mouton@dpw.gov.za
-
- 4** Department of Public Works (Durban), Room 8, West Street, Government Offices, corner of Aliwal and West Streets, Durban, or Private Bag X54315, Durban, 4000; or deposited in the tender box (Box No. 76) at Room 8, Ground Floor, West Street, Government Offices, corner of Aliwal and West Streets, Durban.
Enquiries: Miss C. Noble (Room 11) **Office hours:** 08:00–12:00 and 13:30–15:00
 Tel. (031) 332-1211 x 2160, Fax (031) 332-5485 Mondays to Fridays
 C. Majozi
 Tel. (031) 332-1211 x 2074, Fax (031) 332-5485
-
- 5** Department of Public Works (Bloemfontein), Rooms 410, 411, 412, 413, 416, 417 and 418, Fourth Floor, Civilia Building, 14 Elizabeth Street, Bloemfontein, or Private Bag X20605, Bloemfontein, 9300; or deposited in the tender box at the main entrance, Ground Floor, Civilia Building, 14 Elizabeth Street, Bloemfontein.
Enquiries: DJ van Niekerk/Mr T. Monste/Mr S. Nzuzza/Ms C. Mgijima **Office hours:** 07:30–12:45 and 13:30–15:30
 Tel. (051) 400-8742/8754/8743/8745 Mondays to Fridays
 Fax (051) 400-8872
-
- 6** National Department of Public Works, Johannesburg Regional Office, 78 De Korte Street, corner of De Korte and De Beer Streets, Private Bag X3, Braamfontein; bids/tenders to be deposited in the tender/bid box at the main entrance at the Ground Floor at 78 De Korte Street, Braamfontein.
Enquiries: Mr L. M. Mokone **Office hours:** 07:30–16:00
 Tel. (011) 713-6131, Fax (011) 403-8757, Mondays to Fridays
 Ms R. K. Ramavhoya
 Tel. (011) 713-6044, Fax (011) 403-8757
-
- 7** Department of Public Works, 21–23 Market Square, Old Magistrates Building, Kimberley, 8301; or Private Bag X5002, Kimberley, 8300; or deposited in the tender box at the entrance at 21–23 Market Square, Old Magistrates Building, Kimberley, 8301.
Enquiries: Ms G. Aysen/F. Lemmetjies **Office hours:** 07:30–12:45 and 13:30–16:00
 Tel. (053) 838-5273, Fax (053) 833-5232 Mondays to Fridays
-
- 8** Department of Public Works (Port Elizabeth), Room 402, Eben Dönges Building, corner of Hancock and Robert Streets, North End, Port Elizabeth, or Private Bag X3913, North End, 6056; or deposited in the tender box at Box 4, Room 293–294, Second Floor, Eben Dönges Building, corner of Hancock and Robert Streets, North End, Port Elizabeth.
Enquiries: Mr J. W. Campher **Office hours:** 08:00–12:45 and 13:30–16:30
 Tel. (041) 54-6611, Fax (041) 57-3789 Mondays to Fridays
-
- 9** Department of Public Works (Port Elizabeth), Room 292, Second Floor, Eben Dönges Building, corner of Hancock and Robert Streets, North End, Port Elizabeth, 6056, or Private Bag X3913, North End, 6056; or deposited in the tender box at Box 1–4, Room 293–296, Second Floor, Eben Dönges Building, corner of Hancock and Robert Streets, North End, Port Elizabeth.
Enquiries: Ms M. Carolus/Mr P. Blouw **Office hours:** 08:00–12:45 and 13:30–16:00
 Tel. (041) 408-2035/2033, Fax (041) 487-2209 Mondays to Fridays

-
- 10** Department of Public Works (Mthata Sub Regional Office), Fifth Floor, PRD II Building, Sutherland Street, Mthata; or National Public Works, Tender Section, Private Bag X5007, Mthata, 5100.
Enquiries: N. Mqwebedu
 Tel. (047) 502-7076
Office hours: 08:00–12:45 and 13:30–16:30
 Mondays to Fridays
-
- 11** The Procurement Officer: Mineral and Energy Affairs, Room A-812, Eighth Floor, A-Wing, Mineralia Centre, corner of Visagie and Andries Streets, or Private Bag X59, Pretoria, 0001; or deposited in the tender box in the foyer, Mineralia Centre, 234 Visagie Street, Pretoria. Bids available on website: tenders.dme.gov.za (responses on tender request on E-mail: tenders@dme.gov.za) from **18 October 2004**. Hard copies of tenders will be available at DME Offices.
Enquiries: Bongwiwe Sithembile
 Tel. (012) 317-8744/8053, Fax. (012) 320-8716
Office hours: 07:15–12:30 and 13:15–15:45
 Mondays to Fridays
-
- 20** Government Communication and Information System (GCIS), 356 Midtown Building, c/o Vermeulen and Prinsloo Streets, Pretoria, or Private Bag X745, Pretoria, 0001; or deposited in the tender box at reception, 356 Midtown Building, corner of Vermeulen and Prinsloo Streets, Pretoria, 0001.
Enquiries: **Technical related:**
 Mrs Ntombifuthi Gumede, (012) 314-2226,
 Dr Marietjie Strydom, Tel. (012) 314-2174
Bid procedures: G Storey & M Moreroa,
 Tel. (012) 314-2464, Tel. (012) 314-2246
 Fax (012) 323-3831
Office hours: 07:45–16:15
 Mondays to Fridays
-
- 63** National Department of Public Works, 251 Skinner Street, AVN Building; Private Bag X229, Pretoria, 0001; or deposited in the tender box at Ground Floor, Room GO 20, at the counter.
Please indicate tender no. and the closing date on envelope. Tenders that are received late will not be considered.
Enquiries: Ms E. Burger/Mr Josias Raphesu/Ms S. Ndlovu/
 Ms M. Manala
 Tel. (012) 310-5148/5125/5965, Fax (012) 310-5915
Office hours: 7:30–12:45 and 13:30–16:00
 Mondays to Fridays
-
- 64** The Government Printer: The Government Printing Works, Tender Section, Room 17, 149 Bosman Street corner of Proes Street, Pretoria, or Private Bag X85, Pretoria, 0001; or deposited in the tender box at 149 Bosman Street, next to Main Entrance, Pretoria.
Application for tender documents, fax your request on your company letterhead stipulating the tender numbers required, or collect at Room 17.
Enquiries: Ms S. Kruger/Ms M. M. Mokgonya
 Tel. (012) 334-4597/4680/4611, Cell 082 809 2176
 Fax (012) 323-0009/326-4442/334-8523
Office hours: 07:15–16:00
 Mondays to Fridays
-
- 68** The Director-General: Department of Environmental Affairs and Tourism, Second Floor, Fedsure Forum, 315 Pretorius Street, Pretoria, 0002, or Private Bag X447, Pretoria, 0001; or deposited in the tender box at main entrance, Second Floor, Fedsure Forum, 315 Pretorius Street, Pretoria, 0002.
Enquiries: Mrs I. J. Lensley
 Tel. (012) 310-3558
 Fax (012) 320-3328/2682
Office hours: 07:15–15:45
 Mondays to Fridays
-
- 71A** The Director-General: National Department of Housing, Govan Mbeki House, 240 Walker Street, Sunnyside, Pretoria, 0002, or Private Bag X644, Pretoria, 0001; or deposited in the tender box at main entrance, Govan Mbeki House, 240 Walker Street, Sunnyside, Pretoria.
Enquiries: Mrs A Y Venter/Ms M Hitge/Mr H. Steenkamp
 Tel. (012) 421-1355/421-1307/421-1337
Office hours: 07:30–16:00
 Mondays to Fridays
-
- 76** Department of Labour, Room 510b, Fifth Floor, Boland Bank Building, 42A Schoeman Street, Polokwane, 0700; or Private Bag X9368, Polokwane, 0700; or deposited in the tender box at main entrance, next to the lifts.
Please note: The bid box is situated at the entrance of Boland Bank Building, just next to the lifts. The bid box is open for 24 hours.
Enquiries: Mr Ndanduleni Manwadu
 Tel. (015) 290-1624, Fax (015) 290-1740
Office hours: 07:30–16:00
 Mondays to Fridays
-
- 78** The Provincial Director: Department of Labour, KwaZulu-Natal, 12th Floor, Salmon Grove Chambers, 407 Smith Street, Durban, or P.O. Box 940, Durban, 4000; or deposited in the tender box at Room 1205, 12th Floor, Salmon Grove Chambers, Durban.
Enquiries: Martin Zulu/Humphrey Msomi/Nokuthula Majola
 Tel. (031) 366-1502/2073/2083
 Fax (031) 366-2300
Office hours: 07:30–16:00
 Mondays to Fridays
-
- 90** The Head: National Logistics: SA Police Service, 117 Cresswell Road, Silverton, 0127, or Private Bag X254, Pretoria, 0001; or handed in at Room 5153/5114, First Floor, East Wing, A-Block, 117 Cresswell Road, Silverton, 0127.
Prospective tenderers must request all tenders by fax.
Enquiries: Pac Kola, Tel. (012) 841-7679
 Fax (012) 841-7071
Office hours: 07:30–16:00
 Mondays to Fridays

-
- 95** Department of Water Affairs and Forestry, Ground Floor, ZwaMadaka Building, 157 Schoeman Street, cnr Schoeman and Bosman Streets, Pretoria, 0002; or corner of Schoeman and Bosman Streets, Zwamadaka Building, Pretoria, 0001; or Private Bag X313, Pretoria, 0001.
- Enquiries:** Mr. Victor Malebye/Mrs Hester van der Merwe, **Office hours:** 07:15–16:00
Mr Nicodemus Sekgothe Mondays to Fridays
Tel. (012) 336-8988/7725/7418, Fax (012) 325-6111
-
- 95A** Department of Water Affairs and Forestry, Ground Floor, ZwaMadaka Building, 157 Schoeman Street, cnr Schoeman and Bosman Streets, Pretoria, 0002; or corner of Schoeman and Bosman Streets, Zwamadaka Building, Pretoria, 0001; or Private Bag X313, Pretoria, 0001.
- Enquiries:** Mr Daniel Mokoena/Mr Khomotso Chipane, **Office hours:** 07:15–16:00
Tel. (012) 336-8853/7696, Fax (012) 325-6111 Mondays to Fridays
-
- 95B** Department of Water Affairs and Forestry, Ground Floor, ZwaMadaka Building, 157 Schoeman Street, cnr Schoeman and Bosman Streets, Pretoria, 0002; or corner of Schoeman and Bosman Streets, Zwamadaka Building, Pretoria, 0001; or Private Bag X313, Pretoria, 0001.
- Enquiries:** Mr. Victor Malebye/Mr Hlulani Shirilele, **Office hours:** 07:15–16:00
Tel. (012) 336-8988/8366, Fax (012) 325-6111 Mondays to Fridays
-
- 110** SA Police Service, 117 Cresswell Road, Silverton, 0127, or The Divisional Commissioner, Supply Chain Management, The Section Head, Acquisition Management, Private Bag X254, Pretoria, 0001; or deposited in the tender box at A-Block, First Floor, West Wing, Room 5104.
- Prospective tenderers can come and collect tender documents themselves or can request it by fax.**
- Enquiries:** Mrs Van Wyngaardt **Office hours:** 08:00–15:30
Tel. (012) 841-7459/7551, Mondays to Fridays
Fax (012) 841-7482/7574/7071
E-mail: vwyngaardta@saps.org.za
-
- 113** National Department of Public Works, 9th Floor, Nedbank Centre, 30 Brown Street, Nelspruit CBD, 1200, Mpumalanga; or Private Bag X11280, Nelspruit, 1200; or deposited in the tender box at 9th Floor, Nedbank Building, Nelspruit, 1200.
- Enquiries:** P. Makgato (Tender Office), **Office hours:** 07:30–12:45 and 13:30–16:00
Tel. (013) 753-6312 Mondays to Fridays
Fax (013) 755-4276/1705,
E-mail: Petrus.Makgato@dpw.gov.za
-
- 115** The Director-General: National Department of Agriculture, Agriculture Place, Main Entrance, Tender Receipt Office, Room A-GF-06, 20 Beatrix Street, Arcadia, Pretoria; or Private Bag X250, Pretoria, 0001.
- Enquiries:** M. Mashigo/M. K. Maserumule **Office hours:** 07:30–12:30 and 13:15–16:00
Tel. (012) 319-7129, Fax (012) 319-6888 Mondays to Fridays
-
- 116** Department of Social Development, Human Science Research (HSRC) Building, Room N343, 134 Pretorius Street, Pretoria, 0001; or Department of Social Development, Private Bag X901, Pretoria, 0001; or deposited in the tender box at Reception, Ground Floor, Human Science Research Council, HSRC Building, 134 Pretorius Street, 0001.
- Enquiries:** Mr K Watson/A Maulaudzi, Tel. (012) 312-7566/ **Office hours:** 07:30–12:00 and 13:00–16:00
312-7708, Fax (012) 312-7073 Mondays to Fridays
-
- 145** The Area Manager: Correctional Services: Bethlehem, President Boshoff Street, Bethlehem, or Private Bag X59, Bethlehem, 9700; or handed in at Correctional Services, Logistics, Bethlehem.
- Enquiries:** Mr J. Koorsen **Office hours:** 07:30–12:00 and 13:00–15:45
Tel. (058) 303-3927, Fax (058) 303-7633 Mondays to Fridays
-
- 178** The Area Manager: Correctional Services: Grootvlei, De Wetsdorp Road, Bloemfontein, or Private Bag X20547, Bloemfontein, 9300; or handed in at Correctional Services, Logistics, Grootvlei Prison, Bloemfontein.
- Enquiries:** Mrs K. Scholtz, Tel. (051) 505-4628, **Office hours:** 07:30–12:00 and 13:00–15:45
Fax (051) 440-3663, Cell 082 411 0123 Mondays to Fridays
-
- 179** The Area Manager: Correctional Services: Harrismith, end of Laksman Street, Harrismith, or Private Bag X877, Harrismith, 9880; or handed in at Correctional Services, Logistics, Harrismith.
- Enquiries:** Mr M. S. Mapolala **Office hours:** 07:30–12:00 and 13:00–15:45
Tel. (05861) 2-1040, Fax (05861) 3-0726 Mondays to Fridays
-
- 183** The Area Manager: Correctional Services: Hennenman, corner of Voortrekker and Totius Streets, Hennenman, or Private Bag X8, Hennenman, 9445; or handed in at Correctional Services, Logistics, Hennenman.
- Enquiries:** Mr De Wet **Office hours:** 07:30–12:00 and 13:00–15:45
Tel. (05776) 3-1940, Fax (05776) 3-2548 Mondays to Fridays

-
- 184** The Commissioner: Department of Correctional Services: Church Street, Poynton Building, Pretoria, or Private Bag X136, Pretoria, 0001; or handed in at Directorate Procurement: Correctional Services, West Bock, Second Floor, Room 223.
- Enquiries:** Ms PP Kgwele/Mr C Aries,
Tel. (012) 307-2840/(012) 305-8151
Fax. (012) 323-5621
- Office hours:** 07:30–12:00 and 13:00–15:00
Mondays to Fridays
-
- 193** The Area Manager: Correctional Services: Kroonstad, corner of Vlasblom and Witkantblom Streets, Britz Street, Kroonstad, or Private Bag X23, Kroonstad, 9500; or handed in at Correctional Services, Logistics, Kroonstad.
- Enquiries:** W. J. Viljoen/S. Williams/J. M. Dyman
Tel. (056) 216-4306/4407/4307, Fax (056) 212-9925
- Office hours:** 07:30–12:00 and 13:00–15:45
Mondays to Fridays
-
- 217** The Area Manager: Correctional Services: Odendaalsrus, c/o Freeziat Erika, Odendaalsrus, or Private Bag X6, Odendaalsrus, 9480; or handed in at Correctional Services, Logistics, Odendaalsrus.
- Enquiries:** Mr V. Dansey
Tel. (057) 4-2107, Fax (057) 398-2483
- Office hours:** 07:30–12:00 and 13:00–15:45
Mondays to Fridays
-
- 242** The Area Manager: Correctional Services: Ventersburg, Swart Street, Ventersburg, or Private Bag X2, Ventersburg, 9450; or handed in at Correctional Services, Logistics, Ventersburg.
- Enquiries:** Mr C. J. Haasbroek
Tel. (05777) 4043, Fax (05777) 5218
- Office hours:** 07:30–12:00 and 13:00–15:45
Mondays to Fridays
-
- 246** The Area Manager: Correctional Services: Virginia, Bloudrif Road, Virginia, or Private Bag X15, Virginia, 9430; or handed in at Correctional Services, Logistics, Virginia.
- Enquiries:** Mr S. P. Ntatsane
Tel. (057) 212-3107, Fax (057) 212-6114
- Office hours:** 07:30–12:00 and 13:00–15:45
Mondays to Fridays
-
- 300** Provincial Administration Western Cape: Chief Directorate: Works, Department of Transport and Public Works, Room 701, 9 Dorp Street, Cape Town, 8001, or Private Bag X9078, Cape Town, 8000.
- Enquiries:** Mr G de la Cruz/Mr J. Burricks/Mr M. Bokolo/
Ms n. Nabe, Tel. (021) 483-4604/5240/5240/5425
Fax (021) 483-2488
- Office hours:** 08:00–12:00 and 13:30–15:00
Mondays to Fridays
-
- 323** Gauteng Shared Service Centre, Procurement Office, 6/7th Floor, Imbumba House, 75 Fox Street; Private Bag X091, Marshalltown, 2107, tender documents obtainable from Imbumba House, 75 Fox Street, Marshalltown, Ground Floor, Tender Issue Desk.
- Enquiries:** GSSC Call Centre
Tel. (011) 689-6416/8337, Fax (011) 355-2300
-
- 324** National Department of Works: Mmabatho Regional, Room 106, First Floor, West Gallery, Mega City Shopping Complex, Mmabatho, North West Province, or Private Bag X120, Mmabatho, 2735; or deposited in the tender box at First Floor, West Gallery, Mega City Complex, next to the lift and main entrance.
- Enquiries:** Mr Badisa Motlathledi/Mr Wilson Phaswane
Tel. (018) 384-9331-5 X2308, Fax (018) 384-1386
- Office hours:** 07:00–12:45 and 13:30–16:00
Mondays to Fridays
-
- 325** The Chief Director: Tygerberg Academic Hospital, Room 79, First Floor, Administration Building, Francie van Zyl Drive, Parow Valley, 7500, or Private Bag X3, Tygerberg, 7505; or deposited in the tender box (opposite the spiral staircase) at Tygerberg Hospital, First Floor, Administration Building, Francie van Zyl Drive, Tygerberg.
- Enquiries:** Mrs M. Visser/Mrs C. van Renen
Tel. (012) 938-5605/5255, Fax (021) 938-4719/5628
- Office hours:** 07:30–13:00 and 13:30–16:00
Mondays to Fridays
-
- 352** Provincial Administration Western Cape: Department of Transport and Public Works, 9 Dorp Street, Cape Town, 8001; or Private Bag X9078, Cape Town, 8000; or deposited in the tender box in the Foyer, 9 Dorp Street, Cape Town.
- Enquiries:** Mr G de la Cruz/Mr J. Burricks/Mr M. Bokolo/
Ms N Nabe, Tel. (021) 483-4604/5494/5240/5425
Fax (021) 483-2488
- Office hours:** 08:00–12:00 and 13:30–15:00
Mondays to Fridays
-
- 360** Simonstown Procurement Service Centre, Tender Administration Section, Arsenal Road, Simonstown, 7975; or Department of Defence, Departmental Acquisition and Procurement Division, Simonstown Procurement Service Centre, PO Box 685, Simonstown, 7995; or deposited in the tender box at the main entrance gate, Old Naval Logistics Base, Arsenal Road, Simonstown, Attention: Tender Office. (All hours—Mondays to Fridays).
- Enquiries:** Mrs C du Toit
Tel. (021) 787-5086, Fax (021) 787-5134
- Office hours:** 07:30–12:45 and 13:30–15:45
Mondays to Fridays

-
- 362** Correctional Services: Provincial Commissioner KwaZulu-Natal: Eugene Marais Road, Napierville, Pietermaritzburg, or Private Bag X9126, Pietermaritzburg, 3200; or handed in at Correctional Services: Provincial Commissioner KwaZulu-Natal: Eugene Marais Road, Napierville, Pietermaritzburg.
- Enquiries:** M. A. Wright/Mr T. D. Ngcobo/PR Dladla
Tel. (033) 355-7315/6/7
Fax (033) 394-1282
E-mail: Thami.Ngcobo@dcs.gov.za
- Office hours:** 07:15–15:45
Mondays to Fridays
-
- 371A** Department of Defence, Central Procurement Service Centre, Defence Material Division, corner of Van Riebeeck and Stephanus Schoeman Roads (Room 0006), Thaba Tshwane, or Department of Defence, Departmental Acquisition and Procurement Division, Central Procurement Service Centre, Private Bag X1037, Thaba Tshwane, 0143; or deposited in the tender box next to the main entrance to Joint Support Base Garrison, Department of Defence, corner of Van Riebeeck and Stephanus Schoeman Roads, Thaba Tshwane.
- Bidders to phone in advance, to collect bid documents.**
- Enquiries:** Bid Dispatch Office
Tel. (012) 684-2172/2380, Fax (012) 684-2591
- Office hours:** 08:00–12:45 and 13:30–15:30
Mondays to Fridays
-
- 401** South African Weather Service, Bolepi House, 442 Rigel Avenue South, Erasmusrand, Pretoria, or Private Bag X097, Pretoria, 0001; or deposited in the tender box at main entrance, reception area, Bolepi House, 442 Rigel Avenue South, Erasmusrand, Pretoria (open 24 hours per day, 7 days per week).
- Enquiries:** Ms R Botha, Tel. (012) 367-6159,
Fax (012) 367-6459,
E-mail: rosa.botha@weathersa.co.za
- Office hours:** 08:00–16:30
Mondays to Fridays
-
- 409** Provincial Administration: Western Cape: Department of Environmental and Cultural Affairs: RDP Fynbos Working for Water Project, Utilitas Building, 1 Dorp Street, Cape Town, 8000, or Private Bag X9086, Cape Town, 8000; or deposited in the tender box at the main entrance (foyer), Utilitas Building, 1 Dorp Street, Cape Town.
- Enquiries:** Ms Y. Jephtha/B. du Toit
Tel. (021) 483-4225/3195, Fax (021) 483-3394/5112
- Office hours:** 07:30–16:00
Mondays to Fridays
-
- 419** Department of Trade and Industry (DTI), Second Floor, Block B, 77 Meintjies Street, Sunnyside, Pretoria, 0001.
- Enquiries:** ZP Vukeya/S Mtimkulu, Tel. (012) 394-3087/1918.
E-mail: zvukeya@thedti.gov.za/
smtimkulu@thedti.gov.za
- Office hours:** 07:45–12:30 and 14:00–16:00
Mondays to Fridays
-
- 528** Legal Aid Board, 29 De Beer Street, Braamfontein, 2017; or Private Bag X76, Braamfontein, 2017; or deposited in the tender box at the Main Entrance, Ground Floor, Legal Aid House, 29 De Beer Street, Braamfontein, Johannesburg.
- Enquiries:** John Bopape/Dumisani Dlamini/Andrew
Montane/Merriam Rasetsoke,
Tel. (011) 877-2000; Fax (011) 877-2222
- Office hours:** 08:00–16:00
Mondays to Fridays
-
- 540** National Library of South Africa, 239 Vermeulen Street, cnr. Andries and Vermeulen Streets, Pretoria; Private Bag X990, Pretoria, 0001; for deposited in the tender box in the reception area.
- Enquiries:** S. Mentoor
Tel. (012) 401-9700/321-8931, Fax (012) 401-9764
- Office hours:** 08:00–17:00
Mondays to Fridays
-
- 606** The Head: National Logistics: SA Police Service, 57 Esselen Street, Sunnyside, 0002, or P.O. Box 7518, Pretoria, 0001; or deposited in the tender box at Room 5153, First Floor, East Wing, Block "A", 117 Cresswell Road, Silverton, 0127.
- Enquiries:** Mrs Van Wyngaardt
Tel. (012) 841-7459, Fax (012) 841-7482
- Office hours:** 07:30–16:00
Mondays to Fridays
-
- 616** SITA Head Office, 459 Tsitsa Street, Erasmuskloof, Pretoria, South Africa; or PO Box 26100, Monument Park, 0105; or deposited in the tender box situated at the reception area of SITA Head Office at 459 Tsitsa Street, Erasmuskloof, Pretoria, 0181 (main gate).
- Enquiries:** Tender Office Manager
Tel. (012) 482-2315/2538/2462
Fax. (012) 482-2213/2538, e-mail: tenders@sita.co.za
-
- 638** Department of Public Works, National Public Works Polokwane, First Floor (Room 10), Procurement Section, Old Mutual Building, 78 Hans van Rensburg Street, Polokwane, 0700; or at the Regional Manager, Department of Public Works, Private Bag X9469, Polokwane, 0700.
- Enquiries:** See tender description,
Fax (015) 297-6656/293-8051
- Office hours:** 08:00–12:00 and 13:00–15:00
Mondays to Fridays
-
- 709** HWSeta, No. 2 Bradford Road, cnr Smith & Bradford Roads, Bedfordview, 2047; or Private Bag X15, Gardenview, 2047.
- Enquiries:** Bongiwwe Mncube (Ms)
Tel: (011) 607-6900. Fax: (011) 615-4078
- Office hours:** 08:30–17:00
Mondays to Fridays

-
- 731** The South African Social Security Agency, 501 Prodinsa House, Ground Floor, c/o Beatrix and Pretorius Streets, Arcadia, Pretoria, 0001; or Private Bag X55662, Arcadia, Pretoria, 0083.
Enquiries: Ronny Mampana/Deborah Masemola
 Tel. (012) 400-2091/2129, Fax (012) 400-2342
Office hours: 08:00–13:00 and 14:00–16:30
 Mondays to Fridays
-
- 741** Tourism KwaZulu-Natal, Suite 303, 3rd Floor, Tourist Junction, 160 Pine Street, Durban, 4001; P.O. Box 2516, Durban, 4000; or posted in the Tender Box, Ground Floor, Information Office.
Enquiries: Hlengiwe Madondo, Tel. (031) 366-7501
 Fax (031) 305-6693, E-mail: tkzn@iafrica.com
Office hours: Mondays to Fridays
-
- 749** Department of Water Affairs and Forestry, Regional Office (Limpopo), Azmo Place Building, cnr Mbeki and 49 Joubert Streets, Polokwane, 0699; Private Bag X9506, Polokwane, 0700.
Enquiries: Mr Victor Malebye, Tel. (012) 336-8988,
 Mr Hlulani Shirilele, Tel. (012) 336-8366,
 Fax (012) 325-6111
Office hours: 7h15–16h00
 Mondays to Fridays
-
- 780** Department of Sport of Recreation South Africa, Oranje-Nassau Building, 66 Queen Street (c/o Vermeulen & Queen Streets), Pretoria, 0002; Private Bag X896, Pretoria, 0001, or posted in the tender box, Entrance Regent Place Building, 66 Queen Street (c/o Vermeulen & Queen Streets), Pretoria, 0002.
Enquiries: *Technical:* Charl Durand, Tel. (012) 304-5011
Tender: Ms K.J. Tselana, Tel. (012) 304-5251
 Fax 086 660 6691
Office hours: 08:00–16:30
 Mondays to Fridays
-
- 854** Department of Justice and Constitutional Development, Procurement, corner of Pretorius and Prinsloo Street, Pretoria, 0001; Private Bag X81, Pretoria, 0001; or deposited in the tender box at Reception, First Floor, Momentum Building, corner of Pretorius and Prinsloo Streets, Pretoria.
Enquiries: Khathu Raphunga, Tel. (012) 315-1733,
 Fax 086 688 6619, E-mail: kraphunga@justice.gov.za
Office hours: 07:30–16:00
 Mondays to Fridays (working days)
-
- 856** Universal Service and Access Agency of South Africa (USAASA), Building 21, Thornhill Office Park, 94 Bekker Street, Vorna Valley, Midrand; or P.O. Box 12601, Vorna Valley, 1686.
Enquiries: Mr Alex Ngqwebo/Ms Morakane Pitsi
 Tel. (011) 564-1600, Fax. (011) 564-1629.
 www.usaasa.org.za
Office hours: 08:00–16:00
 Mondays to Fridays
-
- 944** Department: Water Affairs and Forestry, Private Bag X11259, Nelspruit, 1200, or Department: Water Affairs and Forestry, Prorum Building, corner of Brown and Paul Kruger Streets, Nelspruit, 1200.
Enquiries: Mrs A. Zwane/Bunny
 Tel. (013) 752-4183, Fax (013) 755-1678/752-2605
Office hours: 08:00–16:30
 Mondays to Fridays
-

**IMPORTANT ANNOUNCEMENT
TO ALL DEPARTMENTS CONCERNED**

Closing times **PRIOR TO PUBLIC HOLIDAYS** *for the*

**GOVERNMENT
TENDER BULLETIN
2007**

to reach the **GOVERNMENT PRINTER** as follows:

*The Tender Bulletin is published every week on **Friday**, and the closing time for the acceptance of tenders which have to appear in the Tender Bulletin on any particular Friday, is **15:00 on the preceding Friday**.*

*Should any Friday coincide with a public holiday, the date of publication of the Tender Bulletin and the closing time of the acceptance of notices will be **15:00 sharp on the following days**:*

NATIONAL TREASURY

(OFFICE OF THE STATE TENDER BOARD)

**CLOSING DATES OF BIDS/ADVERTISEMENT DATES BY NATIONAL TREASURY: CONTRACT
MANAGEMENT OF BIDS OVER THE FESTIVE PERIOD**

Last advertisement date for the year 2007: 14 December 2007 (for bids closing the week of 21 January 2008, advertisements to reach Government Printers on 7 December 2007)

Last closing date of bids for 2007: 14 December 2007 (advertised on 9 November 2007 and the advertisement must reach Government Printer on 2 November 2007)

First advertising date for 2008: 18 January 2008 (Advertisements to reach Government Printers on 7 December 2007)

First closing date of bids for 2008: 21 January 2008.

**NOTE: CONTRACT MANAGEMENT: TENDER INFORMATION CENTRE WILL BE CLOSED FROM
24 DECEMBER 2007 TO 31 DECEMBER 2007.**

Late notices will be published in the subsequent issue, if under special circumstances, a late notice is being accepted, a double tariff will be charged

GOVERNMENT TENDER BULLETIN

OF THE REPUBLIC OF SOUTH AFRICA

Subscription rates:

Local – R30 + 14% VAT per annum

Total R34,20

Overseas – R40 per annum

Printed by and obtainable from the Government Printer, Bosman Street, Private Bag X85, Pretoria, 0001

Publications: Tel: (012) 334-4508, 334-4509, 334-4510
Advertisements: Tel: (012) 334-4673, 334-4674, 334-4504
Subscriptions: Tel: (012) 334-4735, 334-4736, 334-4737
Cape Town Branch: Tel: (021) 465-7531

Gedruk deur en verkrygbaar by die Staatsdrukker, Bosmanstraat, Privaatsak X85, Pretoria, 0001

Publikasies: Tel: (012) 334-4508, 334-4509, 334-4510
Advertensies: Tel: (012) 334-4673, 334-4674, 334-4504
Subskripsies: Tel: (012) 334-4735, 334-4736, 334-4737
Kaapstad-tak: Tel: (021) 465-7531